



**JUPITER AVIONICS**  
C O R P O R A T I O N

## **JRAC-001**

### **Remote Audio Controller**



## **Installation and Operating Manual**

**Rev. B**

**Jupiter Avionics Corporation**  
**1959 Kirschner Road**  
**Kelowna BC**  
**Canada V1Y 4N7**  
**Tel: +1 778 478 2232**  
**Toll-Free: 1 855 478 2232**  
[www.jupiteravionics.com](http://www.jupiteravionics.com)





## Table of Contents

<b>SECTION 1 - DESCRIPTION</b> .....	<b>1</b>
1.1 System Overview.....	1
1.2 Features Overview.....	1
1.3 Inputs and Outputs .....	2
1.3.1 Inputs .....	2
1.3.2 Outputs .....	2
1.3.3 Bi-directional Ports.....	2
1.4 Specifications.....	3
1.4.1 Electrical Specifications .....	3
1.4.2 Mechanical Specifications .....	5
1.4.3 Configuration Connector.....	5
1.4.4 Flammability of Materials.....	5
<b>SECTION 2 – INSTALLATION</b> .....	<b>6</b>
2.1 Introduction .....	6
2.2 Continued Airworthiness.....	6
2.3 Unpacking and Inspecting Equipment .....	6
2.3.1 Warranty .....	6
2.4 Installation Procedures .....	6
2.4.1 Installation Limitations .....	6
2.4.2 Cabling and Wiring .....	6
2.4.3 Mechanical Installation .....	7
2.4.4 In-Line PTT Cordsets.....	7
2.4.5 Post Installation Checks .....	7
2.5 Adjustments and Configuration using ProCS™ .....	8
2.5.1 ProCS™ Setup .....	8
2.5.2 JRAC-001 ProCS Connection .....	8
2.5.3 Configurable Settings .....	9
2.5.4 Other Configuration Features .....	16
2.6 Virtual Control Panel.....	16
2.6.1 Virtual Controls .....	16
2.7 Installation Kit .....	17
2.7.1 Recommended Crimp tools .....	17
2.8 Installation Drawings.....	17
2.8.1 Generation of Custom Drawings .....	17
<b>SECTION 3 – OPERATION</b> .....	<b>18</b>
3.1 Introduction .....	18
3.2 Normal Mode of Operation .....	18
3.2.1 Receiving .....	18
3.2.2 Transmit Operation .....	18
3.2.3 COM5 PTT Operation.....	18
3.2.4 VOX Operation .....	18
3.2.5 Passenger Dropcord Mode Operation.....	19
3.2.6 ICS Operation .....	19
3.2.7 Music Operation.....	19
3.2.8 Alert Operation.....	19
3.3 Emergency Operation Mode.....	19
3.3.1 Auto Emergency Mode .....	19
3.3.2 Selected Emergency Mode.....	20
3.3.3 EMER RADIO SELECT .....	20
<b>Appendix A - Installation Drawings</b> .....	<b>A1</b>
A1 Introduction .....	A1
A2 Installation Drawings.....	A1



<b>Appendix B - Certification Documents</b> .....	<b>B1</b>
B1    Airworthiness Approval .....	B2
B2    Instructions for Continued Airworthiness .....	B2

## JRAC-001 Remote Audio Controller

### SECTION 1 - DESCRIPTION

#### **1.1 System Overview**

The JRAC-001 remote audio controller is part of an aircraft audio system consisting of a control device and the remote audio controller.

The remote audio controller distributes and controls all transceiver, receiver and alert audio in an aircraft. It routes transmission of microphone audio to a selected transceiver and distributes all intercom audio.

The user operates the remote audio controller by the via the control device where control commands are sent to the remote audio controller via a serial data signal. The control commands manage all user selectable functions of the audio system.

The remote audio controller can be used in a stand-alone configuration (one remote audio controller and one control device) or a multiple configuration (multiple remote audio controllers and multiple control devices) to provide redundancy. An emergency operating mode connects the primary user (pilot) to the COM1 or COM2 transceiver, NAV1 or NAV 2 receiver and Direct audio 1 and 2 sources.

The JRAC-001 is set up on a per-installation basis using a configuration cable and a PC running the product configuration application to download system configuration settings via the configuration connector. To facilitate future customizations and certification, neither software nor complex electronic devices will be used in the JRAC-001 design.

#### **1.2 Features Overview**

The JRAC-001 is comprised of four subassemblies. The top (Volume) subassembly provides independent volume controls for each radio receive audio. The second (receive) subassembly includes a 37 pin D-Min connector, which interfaces to the radio receive audio and crew phones. The third (Control) subassembly includes a 15 pin D-Min which interfaces to the control head and a 3.5mm connector for the configuration application. The bottom (transmit) subassembly includes a 50 pin D-Min connector which interfaces to the power and passenger headset connections. This layout minimizes crosstalk and follows industry standard interconnect for multi-user single transmit selector.

Numerous input and output levels are adjustable, several audio paths are selectable, and alert audio analogue waveforms can be loaded using the configuration application ProCS (Product Configuration Software) to write configuration commands via the JA99-001 configuration cable to the configuration connector. The configuration commands set the level of non-volatile digital control potentiometers to control audio signal levels and to non-volatile expander latches which are connected to audio gates to control the audio signal routing. The audio analogue waveforms are stored in non-volatile voice record and playback devices. The alert audio feature is intended for use as a secondary alerting system where another device provides the primary annunciation.

The JRAC-001 supports up to six transceivers and five receivers.

The JRAC-001 has individual VOX gating.

The JRAC-001 supports two Direct Audio inputs to provide audio at a fixed level to the users.

The JRAC-001 supports a CVR output.

The JRAC-001 supports transmit access for three crew members (Pilot, Co-pilot and Passenger 1).

The JRAC-001 supports a two channel Alert Generator. Each alert has a separate key input.

The JRAC-001 provides intercom functions for up to seven users.



### 1.3 Inputs and Outputs

Refer to the JRAC-001 [connector maps](#) for the mating connector designators and pin assignments for the input and output signals.

#### 1.3.1 Inputs

<b>Name</b>	<b>Qty</b>	<b>Type</b>
ALERT ENABLE	1	Active high discrete
ALERT KEY	2	Active low discrete (configured via ProCS)
CALL	1	Active low discrete (configured via ProCS)
EMER RADIO SELECT	1	Two state discrete
CONFIG DATA TO JRAC	2	Data signal
CONTROL DATA TO JRAC	1	Data signal
DIRECT AUDIO 1 HI/LO	1	Audio signal
DIRECT AUDIO 2 HI/LO	1	Audio signal
PILOT ICS PTT	1	Active low discrete
COPILOT ICS PTT	1	Active low discrete
PAX ICS PTT	1	Active low discrete
MIC HI/LO (Seven users)	7	Audio signal
MODE SELECT / CONFIG AUDIO	1	Multi format signal
MUSIC LEFT/RIGHT HI/LO	2	Audio signal
CONTROL PANEL MUSIC L/R	2	Audio signal
NORM MODE SELECT	1	Active low discrete
POWER/GROUND INPUT	1	14 to 28 Vdc power supply
RX HI/LO	11	Audio signal (6 COM, 5 NAV)
RX MUTE	1	Active low discrete
PILOT/COPILOT TX PTT	2	Active low discrete
PAX 1 TX PTT	1	Active low discrete

#### 1.3.2 Outputs

<b>Name</b>	<b>Qty</b>	<b>Type</b>
CALL ANNUNCIATOR	1	Active low discrete
CVR HI/LO	1	Audio signal
CONFIG DATA FROM JRAC	2	Data signal
CONTROL DATA FROM JRAC	1	Data signal
PHN HI/LO	6	Audio signal (6 outputs for driving 7 phones.)
POWER/GROUND FROM JRAC	1	Power output
TIME OUT RESET	1	Active low momentary discrete
COM MIC HI/LO	6	Audio signal (transceiver Mic)
COM PTT	6	Active low discrete
TX ACTIVE	1	Active low discrete
RX COMP OUT HI/LO	1	Audio signal (configured via ProCS)

#### 1.3.3 Bi-directional Ports

<b>Name</b>	<b>Qty</b>	<b>Type</b>
ICS TIE HI/LO	1	Audio signal



## 1.4 Specifications

### 1.4.1 Electrical Specifications

#### Power Input

Primary nominal voltage	28 Vdc
Secondary nominal voltage	14 Vdc
Maximum voltage	32.2 Vdc
Minimum voltage	10.2 Vdc
Emergency voltage	9.0 Vdc
Input current at 28 Vdc	≤ 0.7 A
Input current at 14 Vdc	≤ 1.4 A
Input current at 9 Vdc	≤ 2.4 A

#### 1.4.1.1 Audio Performance

##### Rated Input Level

Receive audio rated input level	7.75 Vrms ±10%
Direct audio 1 rated input level	7.75 Vrms ±10%
Direct audio 2 rated input level	2.50 Vrms ±10%
Music rated input level	400 mVrms ±10%
Microphone input level	250 mVrms ±10%
Intercom Tie Line type 1 input level	340 mVrms ±10%
Intercom Tie Line type 2 input level	1.20 Vrms ±10%
CONFIG AUDIO input level	400mVrms ±10%

##### Rated Output Power

Phone rated output	7.75 Vrms±10%
Pilot Phone rated output, in emergency mode or with power input ≤6 Vdc Or from DIR AUDIO 2 input	2.10 Vrms±10%
Phone rated output power, with MUSIC input	3.88 Vrms±10%
Microphone rated output	250 mVrms±10%
CVR rated output	500 mVrms±10%
CVR rated output with input as MUSIC	250 mVrms±10%
CVR rated output with input as PILOT MIC	1.00 Vrms±10%
CVR rated output, in emergency mode,	500 mVrms ±20%
Receive Composite rated output	2.5 Vrms ±10%
Intercom Tie Line type 1 rated output	340 mVrms ±10%
Intercom Tie Line type 2 rated output	1.2 Vrms ±10%

##### Audio Frequency Response

Audio output audio frequency response	≤3dB from 300 to 6000 Hz
Alert audio output audio frequency response	≤3dB from 300 to 3000 Hz

##### Distortion Characteristics

Audio output distortion at rated power	≤10%
Audio output distortion at 10% of rated power	≤3%

##### Input Impedance

Microphone input Impedance	150 Ω ±10%
Direct Audio 1 input Impedance	1000 Ω ±10%
Direct Audio 2 input Impedance	100 Ω ±10%
Receive Audio input Impedance	1000 Ω ±10%
Music Audio input Impedance	1000 Ω ±10%
Intercom Tie Line Audio input Impedance	2000 Ω ±10%



SELECT MODE / CONFIG AUDIO input impedance	7800 $\Omega$ $\pm$ 10%
<u>Output Impedance</u>	
Headphone output Impedance	$\leq$ 60 $\Omega$
Transceiver Microphone output Impedance	$\leq$ 80 $\Omega$
CVR output Impedance	$\leq$ 80 $\Omega$
Receive Composite Audio output Impedance	$\leq$ 80 $\Omega$
Intercom Tie Line output Impedance	2000 $\Omega$ $\pm$ 20%
<u>Output Load</u>	
Headphone load	600 $\Omega$ $\pm$ 10%
Transceiver Microphone load	150 $\Omega$ $\pm$ 10%
CVR load	5000 $\Omega$ $\pm$ 10%
Receive Composite Audio load	600 $\Omega$ $\pm$ 10%
Intercom Tie Line type 1 rated load	2000 $\Omega$ $\pm$ 10%
Intercom Tie Line type 2 rated load	2000 $\Omega$ $\pm$ 10%
Intercom Tie Line type 1 maximum load	666 $\Omega$ max (3 loads)
Intercom Tie Line type 2 maximum load	285 $\Omega$ max (7 loads)
<u>Volume Controls</u>	
Master Receive Audio control variation	32 $\pm$ 3dB
ICS Audio control variation	42 $\pm$ 3dB
<u>Output Regulation</u>	
Output Regulation change in voltage level	$\leq$ 3 dB
ICS TIE Output Regulation change in voltage level	$\leq$ 7 dB
Output Regulation distortion	$\leq$ 10%
<u>Input to Output Crosstalk and Bleed-through Level</u>	
Input to Output crosstalk	$\leq$ 55 dB
<u>Input to Input Crosstalk Level</u>	
Input to Input crosstalk	$\leq$ 60 dB
<u>Audio Noise Level without Signal</u>	
Noise level below the rated output	$\geq$ 60 dB
<u>1.4.1.2 Audio Performance, Other</u>	
CVR HI / LO output circuitry type (Normal)	differential
CVR HI / LO output circuitry type (Emergency)	single ended
Microphone inputs designed for microphone type	amplified dynamic / electret
Microphone inputs bias voltage	12 Vdc $\pm$ 10%
Microphone inputs circuitry type	single ended
MUSIC LEFT / RIGHT HI / LO audio input circuitry type	differential
MUSIC attenuation	38 dB min
RECEIVE AUDIO input circuitry type	differential
PHN HI / LO output circuitry type	single ended
MIC output circuitry type	differential
RX Composite Audio output circuitry type	differential
ICS TIE HI / LO Circuitry Type	differential
PHN HI / LO output music fade in duration	2.5 $\pm$ 1.0 seconds
VOX Threshold level range relative to rated MIC input	-30 to +12 dB
VOX Off Delay Time accuracy	$\pm$ 0.25 s
VOX Delay Time range	0.5 to 2.0 seconds
Transmit Timer duration	90 $\pm$ 30 seconds
ICS TIE audio detect threshold level from MIC audio input	7 to 9 mV rms
Receive Audio detect threshold control range,	



relative to rated receive audio input -36 to -12 dB

**1.4.1.3 Discrete Signals**

Active low control input, active signal level	≤ +3 Vdc
Active low control input shall be inactive when the signal is	≥ +10 Vdc
Active low control input signals, when active, sources	0.1 to 10 mA
Active low control input signals have an internal pull-up resistor	
Active low control output, active output	≤ +2 Vdc
Active low control output signals, when active, sinks	≤ 1 A
ALERT ENABLE signal is active when the input signal is	≥ +9 Vdc
ALERT ENABLE signal, when active, sinks	0.1 to 10 mA
ALERT ENABLE signal is inactive when the input signal is	≤ +3 Vdc

**1.4.2 Mechanical Specifications**

Height	1.97 in [50.0 mm] max
Depth	6.79 in [172.5 mm] max
Width	5.87 in [149.1 mm] max
Weight	1.64 lbs [0.740 kg] max
Enclosure Material	brushed aluminum with conversion coating
Connectors (4):	J1 One 37-pin D-Sub male V5 locking
	J2 One 50-pin D-Sub male V5 locking
	J3 One 15-pin D-Sub male V5 locking
	J4 One 4 pole 3.5mm stereo jack
	J5 One 4-40 stud, 0.5 in max.
Mounting (2 axes)	4 x 10-32 fasteners
Bonding	≤ 2.5 mΩ
Installation kit part number	INST-JRAC

**1.4.3 Configuration Connector**

The JRAC-001 configuration connector communication standard for CONFIG DATA TO JRAC-001 data input signal and CONFIG DATA FROM JRAC-001 data output signal is RS-232.

**1.4.4 Flammability of Materials**

The JRAC-001 complies with the requirements of RTCA/DO-160G Sec 26.3.3 "Flammability", through equivalent flammability testing of materials and the Small Parts Exemption.



## JRAC-001 Remote Audio Controller

### SECTION 2 – INSTALLATION

#### 2.1 Introduction

This section contains unpacking and inspection procedures, installation information, and post-installation checks.

#### 2.2 Continued Airworthiness

Maintenance of the JRAC-001 is on condition only. Scheduled inspection and/or periodic maintenance of this unit is not required.

#### 2.3 Unpacking and Inspecting Equipment

Unpack the equipment carefully. Check for shipping damage and report any problems to the relevant carrier. Confirm that the Authorized Release Certificate or Certificate of Conformance is included. Complete the on-line warranty card from the Jupiter Avionics Corporation (JAC) website – [www.jupiteravionics.com/warranty](http://www.jupiteravionics.com/warranty).

##### 2.3.1 Warranty

This product manufactured by JAC is warranted to be free of defects in workmanship or performance for 2 years from the date of installation by an approved JAC dealer or agency. This warranty covers the cost of all materials and labour to repair or replace the unit, but does not include the cost of transporting the defective unit to and from JAC or its designated warranty repair centre, or of removing and replacing the defective unit in the aircraft. This warranty does not cover failures due to abuse, misuse, accident, or unauthorized alteration or repairs.

THIS WARRANTY IS VOID IF THE PRODUCT IS NOT INSTALLED BY AN AUTHORIZED JAC DEALER. If the on-line warranty card is not completed, the product will be warranted from the date of manufacture.

Contact JAC for return authorization, and for any questions regarding this warranty and how it applies to your unit(s). JAC is the final arbiter concerning warranty issues.

#### 2.4 Installation Procedures



---

**WARNING:** Loud noise can cause hearing damage. Set the headset volume to minimum before conducting tests, and slowly increase the volume to a comfortable listening level.

---



---

**CAUTION:** The power input circuitry of the unit may be damaged if the installation does not conform to the wiring instructions in this manual.

---

##### 2.4.1 Installation Limitations

The conditions and tests for CAN TSO and FAA TSO approval of the JRAC-001 are minimum performance standards. Those installing the JRAC, on or in a specific type or class of aircraft, must determine that the aircraft installation conditions are within TSO standards. The JRAC-001 may be installed only by following the applicable airworthiness requirements.

##### 2.4.2 Cabling and Wiring

All wire shall be selected in accordance with the original aircraft manufacturer's maintenance instructions, or AC43.13-1B Change 1, Paragraphs 11-76 through 11-78. Unshielded wire types shall qualify to MIL-W-22759 as specified in AC43.13-1B Change 1, Paragraphs 11-85, 11-86, and listed in Table 11-11. For shielded wire applications, use Tefzel MIL-C-27500 shielded wire with tag ring or equivalent (for shield terminations) to make the most compact and easily terminated interconnect. Follow the Connector Map in Appendix A of this manual.



Allow 3" from the end of the shielded wiring to the shield termination to allow the connector hood to be easily installed. Refer to the Interconnect drawing in Appendix A of this manual for shield termination details. Note that this unit has a 'clamshell' hood that is installed after the wiring is complete.

Maintain wire segregation and route wiring in accordance with the original aircraft manufacturer's maintenance instructions.

Unless otherwise noted, all wiring shall be a minimum of 24 AWG, except power and ground lines, which shall be a minimum of 22 AWG. Refer to the Interconnect drawing for additional specifications. Check that the ground connection is clean and well secured, and that it shares no path with any electrically noisy aircraft accessories such as blowers, turn-and-bank instruments, or similar loads.

### 2.4.3 Mechanical Installation

The JRAC-001 can be mounted in any attitude and location with sufficient clearance for the connector and wiring harness. It requires no direct cooling.

### 2.4.4 In-Line PTT Cordsets

If in-line PTT cordsets (drop cords) are used, be aware that incorrectly configured or improperly shielded in-line PTT cordsets can lead to significant audio problems.

### 2.4.5 Post Installation Checks

#### 2.4.5.1 Voltage/Resistance checks.

Do not attach this unit until the following conditions are met:

- a) Check P2 pin **16** for +28 Vdc relative to ground (alert power).
- b) Check P2 pin **17** for +28 Vdc relative to ground.
- c) Check P2 pin **34** for continuity to ground (less than 0.5  $\Omega$ ).
- d) Check P2 pins **7 thru 10** for continuity to ground (less than 0.5  $\Omega$ ) when the relevant switch is closed.
- e) Check P2 pins **11 and 12** (optional connections) for continuity to ground (less than 0.5  $\Omega$ ) when the relevant switch is closed.
- f) Check P3 pin **4** for continuity to ground (less than 0.5  $\Omega$ ) when the relevant switch is closed.
- g) Check P5 (optional connection) for continuity to ground (less than 0.5  $\Omega$ ).
- h) Check all pins for shorts to ground or adjacent pins.

#### 2.4.5.2 Configuration

Ensure that the JRAC-001 contains the correct configuration settings. This may be done at the factory, on the maintenance bench or in the aircraft before the power on checks are performed. Refer to [section 2.5](#).

#### 2.4.5.3 Power on Checks.

Power up the aircraft's systems and confirm normal operation of all functions of the JRAC. Refer to Section 3 (Operation) for specific operational details.

- a) Begin with only the pilot's headset attached. Confirm correct ICS and radio operation for both receive and transmit. Check yoke or cyclic switch action. Check the radio selection and inputs. Do not proceed until the radios are functioning correctly.
- b) If there is a music source in the system, turn it on and check for proper mute operation.
- c) Unusual buzzes, hums or other background audio are symptomatic of multiple grounds, or noisy external systems such as blowers or pumps sharing wiring with the audio system. If a transmitter fails to key or correctly modulate it is often the result of not connecting all required grounds to the radio or external audio system.
- d) Check the ICS operation and Emergency operation.
- e) Plug in the co-pilot's headset. Check for correct ICS operation. Check yoke or cyclic switch functions.



- f) Plug in any remaining headsets, and check for correct ICS operation. Note that an incorrect cordset (drop cord) or improper jack wiring may cause a wide range of problems, from loss of audio to a tone heard in the headset.
- g) Check that all configuration settings are correct.

When all performance checks are satisfied, complete the necessary regulatory documentation before releasing the aircraft for service. Refer to [Appendix B](#).

## 2.5 Adjustments and Configuration using ProCS™

The JRAC-001 configuration adjustments are set from the configuration program ProCS™. Configuration data is sent to the JRAC-001 via the configuration connector (J3), using the configuration program and JA99-001 Configuration Cable.

### 2.5.1 ProCS™ Setup



The JRAC-001 menu item 'ProCS Setup' provides Setup drawings showing the cabling arrangements for connecting the JRAC-001 to a computer to allow configuration using ProCS™, and to allow control of an attached JRAC-001 (see also section [2.6 – Virtual Control Panel](#)).

If the JRAC-001 is installed in a system with a Jupiter Avionics Corporation JCPx-xxx Control Panel, the JRAC-001 may be configured via the front panel /io connector on the control panel. Refer to [Dfc7 G'GYi d'!'>7 D' !\\$\\$%](#)

The connector is located under a port cover which may be lifted clear or rotated to one side, as shown.

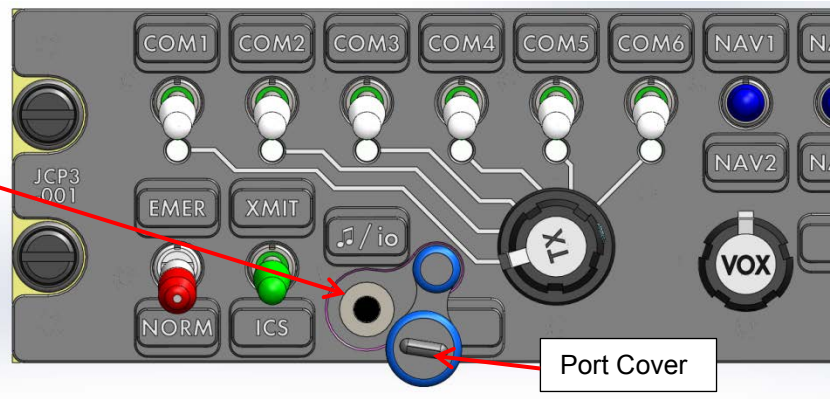

Refer to the [ProCS™ manual](#) for complete information on the configuration process.



**Note:** It is important to be aware that some of the screens shown may appear slightly differently, depending on whether or not a JRAC-001 is connected.

### 2.5.2 JRAC-001 ProCS Connection

Selecting COM ports:



Configuration Port Selection

Control COM Port Selection

JRAC-001 configuration requires one COM port connected to a configuration connector via the JA99-001 Configuration cable. The COM ports are selected from Edit > Options in the main ProCS menu. The Application Options window will open.

The designated Product Configuration COM Port confirmed during ProCS installation (see ProCS Installation and Operation Manual section 2.4.2) can be selected through this window.

The Product Control COM Port is also set from this window.



### 2.5.3 Configurable Settings

A standard unit is shipped from the factory with all internal adjustments configured to the default levels. At installation, it may be desirable to change some of these settings to suit the local operating environment.

Within ProCS™, the configurable settings are grouped together into the following sections:

#### 2.5.3.1 JRAC-001 Virtual Front Panel

##### Legend Assignments

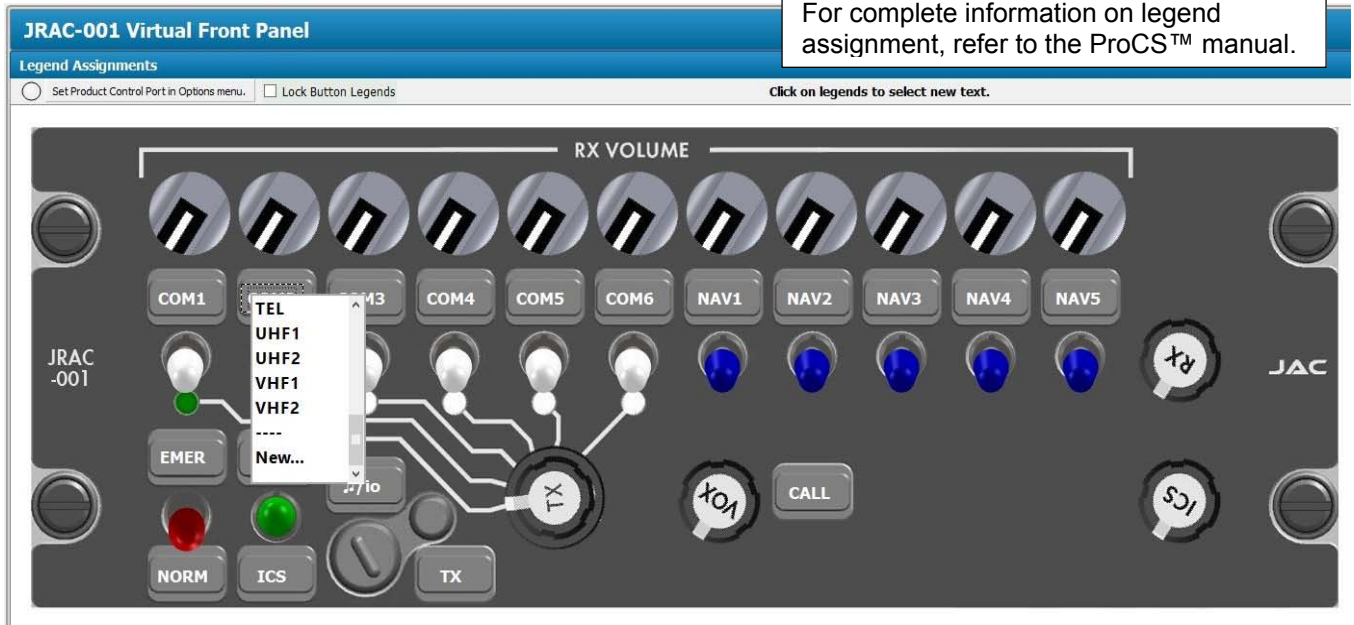

This Virtual Front Panel is used to define the 'names' associated with the control legends. The selected name will be used in all subsequent references to the associated transceiver/receiver, and will be used on the custom-generated Connector Maps and Interconnects. Also see section 2.6 (Virtual Control Panel).

#### 2.5.3.2 JRAC-001 Radios

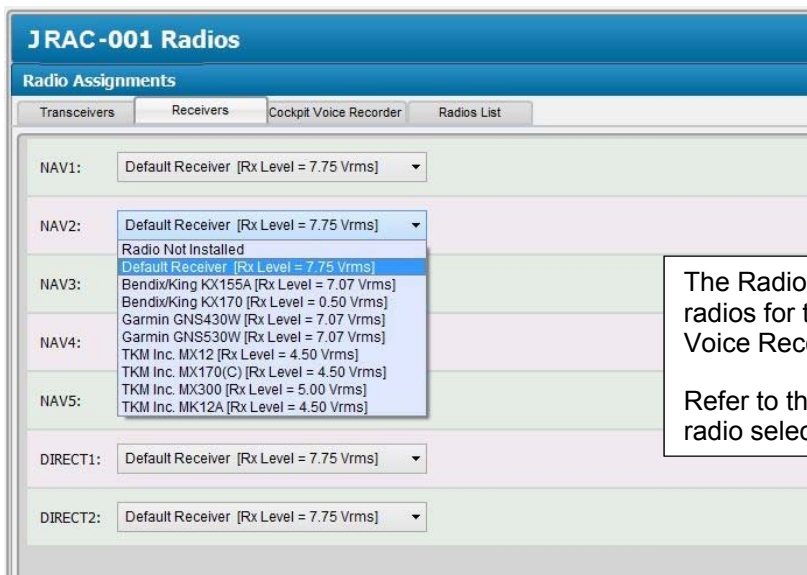

The Radio Assignments window is used to define the radios for the transceivers, receivers and Cockpit Voice Recorder.

Refer to the ProCS™ manual for full information on radio selection.



### 2.5.3.3 JRAC-001 Receive Levels

**JRAC-001 Receive Levels**

**Input Levels**

COM1 Default Transceiver : 1.00 Vrms  10.00 Vrms [7.75 Vrms] Default Level

COM2 Default Transceiver : 1.00 Vrms  10.00 Vrms [7.75 Vrms] Default Level

NAV5 Default Receiver : 1.00 Vrms  10.00 Vrms [7.75 Vrms] Default Level

DIRECT1 Default Receiver : 1.00 Vrms  10.00 Vrms [7.75 Vrms] Default Level

DIRECT2 Default Receiver : **Note:** DIRECT 2 Rated Input Level is fixed (Not Adjustable)

**Receive Audio Detector**

**0dB = Rated Input Level**

Level: -12 dB  -58 dB Value

**Output Level**

**Rated Load Impedance = 600 Ohms**

Receive Composite: 0.25 Vrms  2.50 Vrms [1.00 Vrms]

**Note:** The Receive Composite pin is configured on the [Connector Pin Configuration](#) page.

#### Input Levels

The receive and direct audio input level of each of COM1-6, NAV1-5 and DIRECT1 inputs can be adjusted from 1 to 10 Vrms. **(Default 7.75 Vrms)**

#### Receive Audio Detector

The Receive Audio Detector threshold can be adjusted from -58 to -12 dB of rated input level.

#### Output Level

The level of the receive composite audio output (RX COMP OUT) can be adjusted from 0.25 to 2.5 Vrms. **(Default 1.0 Vrms)**



### 2.5.3.4 JRAC-001 Transmit Levels

**JRAC-001 Transmit Levels**

**Transmit Levels**

Rated Load Impedance = 150 Ohms

COM	Default Transceiver	Output Level	Default Level
COM1	0.010 Vrms	0.250 Vrms	Default Level
COM2	0.010 Vrms	0.250 Vrms	Default Level
COM3	0.010 Vrms	0.250 Vrms	Default Level
COM4	0.010 Vrms	0.250 Vrms	Default Level
COM5	0.010 Vrms	0.250 Vrms	Default Level
COM6	0.010 Vrms	0.250 Vrms	Default Level

**Transmit Settings**

- Transmit Time-out (90 Sec.)
- COM5 Duplex

#### Transmit Levels

The level of each of the six Transceiver MIC output signals can be adjusted from 0.010 to 1.000 Vrms. **(Default 0.250 Vrms)**

#### Transmit Settings

When the Transmit Timeout check box is checked the transmit time-out is enabled **(Default not checked)**

When the COM5 Duplex check box is checked the COM5 radio is set to duplex operation **(Default not checked)** (see section 3.2.3)

### 2.5.3.5 JRAC-001 Sidetone Levels

**JRAC-001 Sidetone Levels**

**Receive Sidetone Level**

Level 0 dB -12 dB [-6 dB]

The Receive Sidetone Level can be adjusted from -12 to 0 dB of the rated phone Level. **(Default -6 dB)**

**COM6 Artificial Sidetone Level**

0dB = Rated Phone Level

COM6 0 dB -30 dB [-10 dB]

The COM6 Artificial Sidetone Level output on the phones audio can be adjusted from -30 to 0 dB. **(Default -10 dB)**



### 2.5.3.6 JRAC-001 Connector Pin Configuration

Several of the connector pins can be configured to meet the requirements of specific installations.

Refer to JRAC-001 [Interconnect sheets 5 and 6](#).

**JRAC-001 Connector Pin Configuration**

**J1 Contacts Selection**

Pin 1/20:  CVR HI/LO OUTPUT  DIRECT AUDIO 2 HI/LO INPUT

Pin 14/33:  MUSIC LEFT HI/LO INPUT  RX COMP HI/LO OUTPUT

**J2 Contacts Selection**

Pin 6:  PAX 1 TX PTT INPUT  MF SW 2 OUTPUT (ICS)

Pin 11:  PAX 1 ICS PTT INPUT  ALERT 1 KEY INPUT  MF SW 1 OUTPUT (XMIT)

Pin 12:  ALERT 2 KEY INPUT  CALL INPUT

**J3 Contacts Selection**

Pin 13:  RESET OUTPUT  RESET INPUT

Several of the J1 and J2 connector pins can be configured to suit individual installations. The default settings are **bolded**.

Pin 13 of the J3 connector can be configured as an input/output reset. The default setting is **bolded**.

#### J3 Contacts selection - Pin 13 Reset

If Pin 13 is selected as Reset Input, it can be wired to accept an external reset signal.

If Pin 13 is selected as Reset Output, a 'watchdog' signal is received from the remote control panel at known intervals. If the signal is not received, the Reset Output signal is activated to attempt a restart of the 'failed' device.

### 2.5.3.7 JRAC-001 Alerts



**WARNING:** The internal audio alerts are intended only to supplement, NOT replace, airframe alerts such as 'low rotor RPM', 'engine out' or 'decision height alerting'. The alert audio feature is intended for use as a secondary alerting system where another device provides the primary annunciation.

The JRAC-001 has standard audio signals for each of the two alerts, and the audio files window allows these signals to be customized with other recordings during the configuration process.

**JRAC-001 Alerts**

Clicking on 'Open...' allows browsing access for selection of a suitable .wav file. If a file is selected, a 'Play' button will appear to the right of the selected file.

**Audio Files**

Alert 1 (6s max): JRAC-001 Wav File (Alert1 - 2 tone alt - 6 s)Rev A.wav

Alert 2 (6s max):

Store alerts in data file

The default Alert signals loaded into the unit at the factory are:

JRAC-001 Wav File (Alert1 - 2 tone alt - 6 s) Rev A.wav  
JRAC-001 Wav File (Alert2 - swept tone - 6 s) Rev A.wav



### Audio Levels

The levels of the two Alert Audio signals are individually adjustable from -40 to 0 dB of the rated phone level. **(Default -12 dB)**

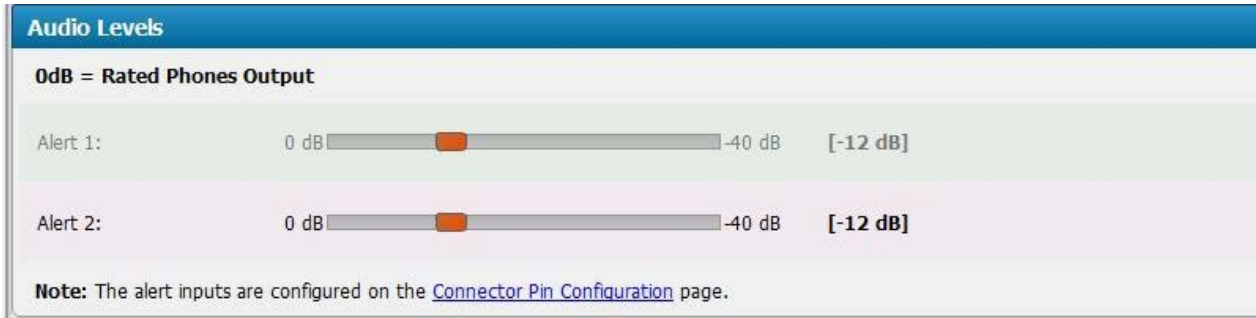

### Record Audio Alerts

When a JRAC-001 is connected to ProCS™ a Record Audio Alerts window will be available.

If 'Record JRAC-001 Alerts ...' is selected from the Program menu, a red bar will show the progress of the recording, and the meter to the right of the bar will show the duration of the alert.

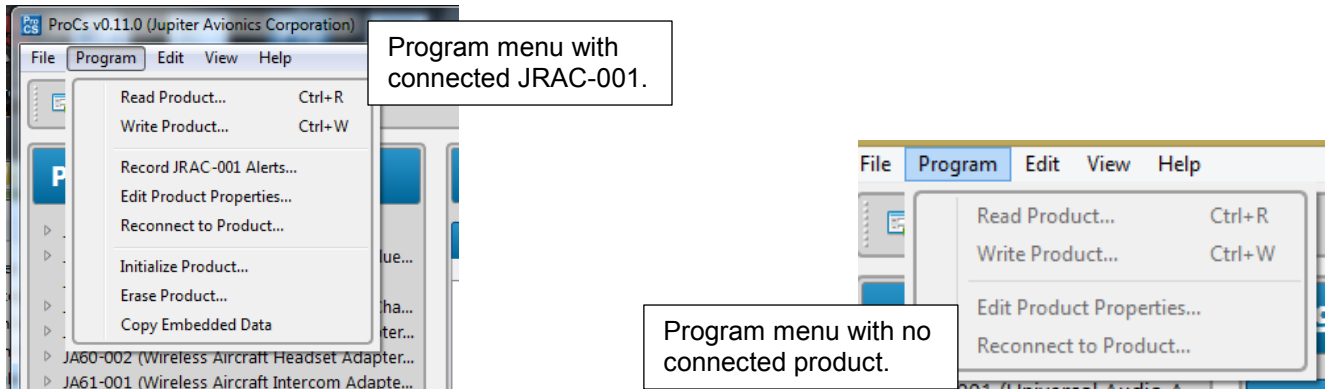
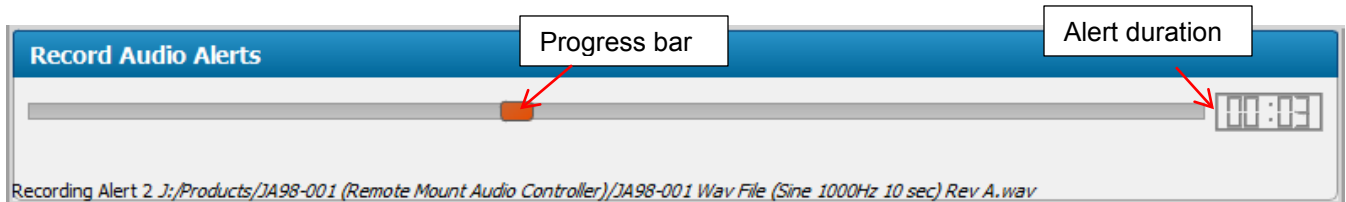

### 2.5.3.8 JRAC-001 Audio Muting (During Transmit)

When the Mute RX Audio check box is checked the Receive Audio is muted during transmit **(Default checked)**

When the Mute ICS Audio check box is checked the ICS Audio is muted during transmit **(Default checked)**

When the Mute Alert Audio check box is checked the Alert Audio is muted during transmit **(Default not checked)**

The Mute Music Audio check box is checked and Music Audio is always muted during transmit.





### 2.5.3.9 JRAC-001 CVR Level

The screenshot shows the 'JRAC -001 CVR Level' configuration page. It features a blue header with the title. Below is a section titled 'CVR Audio Output Levels' with a sub-section 'Rated Load Impedance = 5 kOhms'. There are three rows of sliders: 'Receive Only' (range 0.010 to 1.000 Vrms, default 0.500 Vrms), 'Pilot Mic Only' (range 0.020 to 2.000 Vrms, default 1.000 Vrms), and 'Music Only' (range 0.005 to 0.500 Vrms, default 0.250 Vrms). A 'Note' section at the bottom contains two points: '1. All Inputs at rated level.' and '2. Where applicable, rated level on phones output.'

The level of the Cockpit Voice Recorder audio may be adjusted from 0.01 to 1 Vrms. (**Default 0.50 Vrms**)

### 2.5.3.10 JRAC-001 Music Levels

The screenshot shows the 'JRAC-001 Music Levels' configuration page. It has a blue header with the title. Below is a section 'Music Output Level' with a sub-section '0dB = Rated Phone Level'. It contains two sliders: 'Output Level' (range 0 dB to -40 dB, default 0 dB) and 'Attenuation Level (During Mute Function):' (range 0 dB to -40 dB, default -40 dB). Below this is a 'Music Settings' section with a checkbox 'Configure NAV4 Switch as Rear Music Selector'. The bottom section is 'Music Input Level' with two sliders: 'Music Left:' (range 0.10 Vrms to 1.00 Vrms, default 0.40 Vrms) and 'Music Right:' (range 0.10 Vrms to 1.00 Vrms, default 0.40 Vrms).

#### Music Output Level

The music output level of the two Music input signals to the Phones audio can be adjusted from -40 to 0 dB of rated phone level (**Default 0 dB**).

The attenuation level during muting of the music signal can be adjusted from -40 to 0 dB (**Default -40 dB**).



2.5.3.11 **JRAC-001 ICS Tie Line**

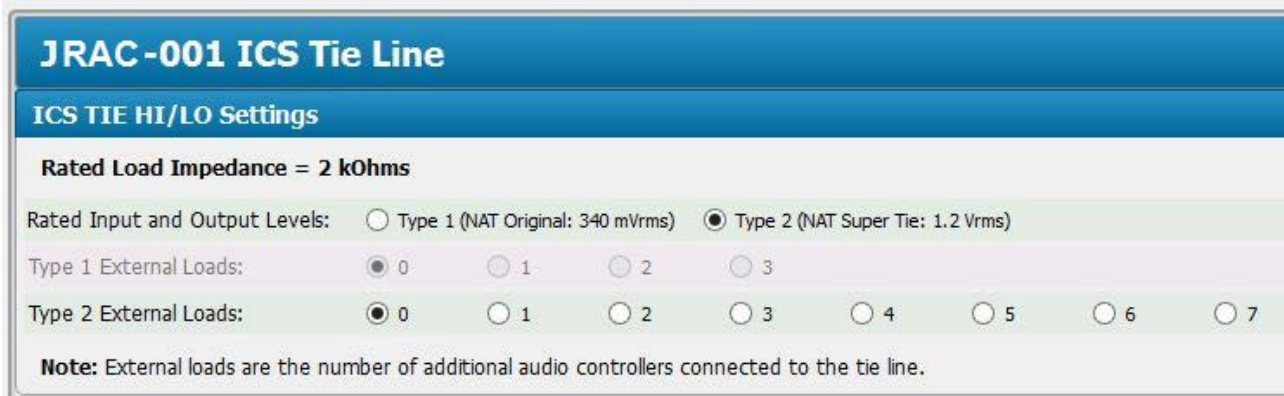

The rated input and output levels of the intercom tie line can be selected as Type 1 or Type 2 (**Default Type 2**).

The quantity of external loads for a type1 intercom tie line can be selected from 0 to 3 (**Default 0**).

The quantity of external loads for a type 2 intercom tie line can be selected from 0 to 7 (**Default 0**).

2.5.3.12 **JRAC-001 VOX**

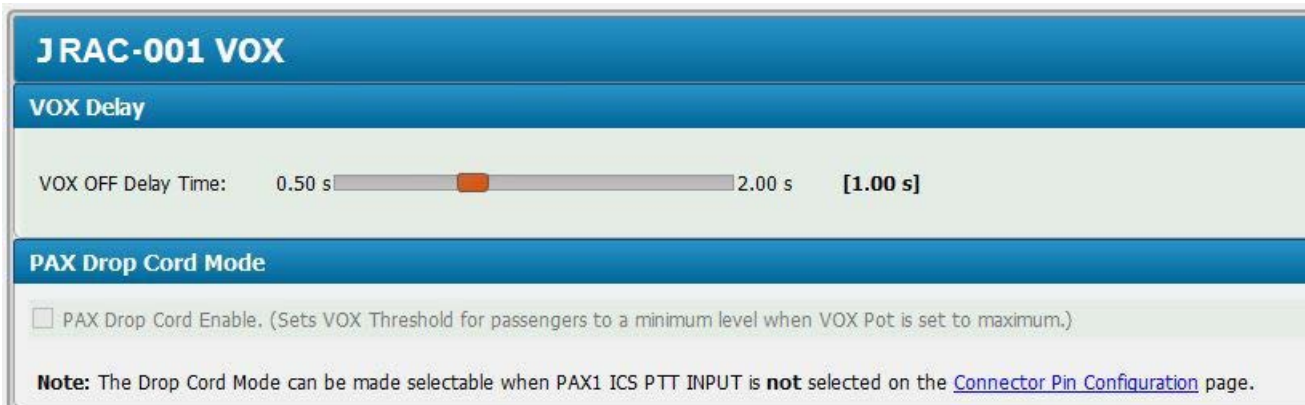

VOX Delay

The VOX OFF Delay Time can be adjusted from 0.50 to 2.00 sec (**Default 1.00 sec**).

PAX Drop Cord Mode

When the PAX Drop Cord Enable check box is checked, the VOX circuits for the passenger microphones are configured for use with drop cords (**Default not checked**).

2.5.3.13 **JRAC-001 Connector Maps**

The Connector Maps section is used to generate custom Connector Maps and Interconnects for use by the installing agency.





## 2.5.4 Other Configuration Features

In the JRAC-001 Product Information Window, the model number, serial number, MOD status and check sum of the JRAC-001 audio panel can be stored and viewed.

## 2.6 Virtual Control Panel

The Virtual Control Panel for the JRAC-001 is a computer application that is part of the ProCS™. The JRAC-001 Virtual Front Panel can be used to temporarily select and control an attached JRAC-001. The Virtual Control Panel communicates with the JRAC-001 via the Product Control Serial Port (see [section 2.5.2](#)). Control data is sent to the JRAC-001 via the control connector (J12) using cable CAB-USB-0008.

### 2.6.1 Virtual Controls

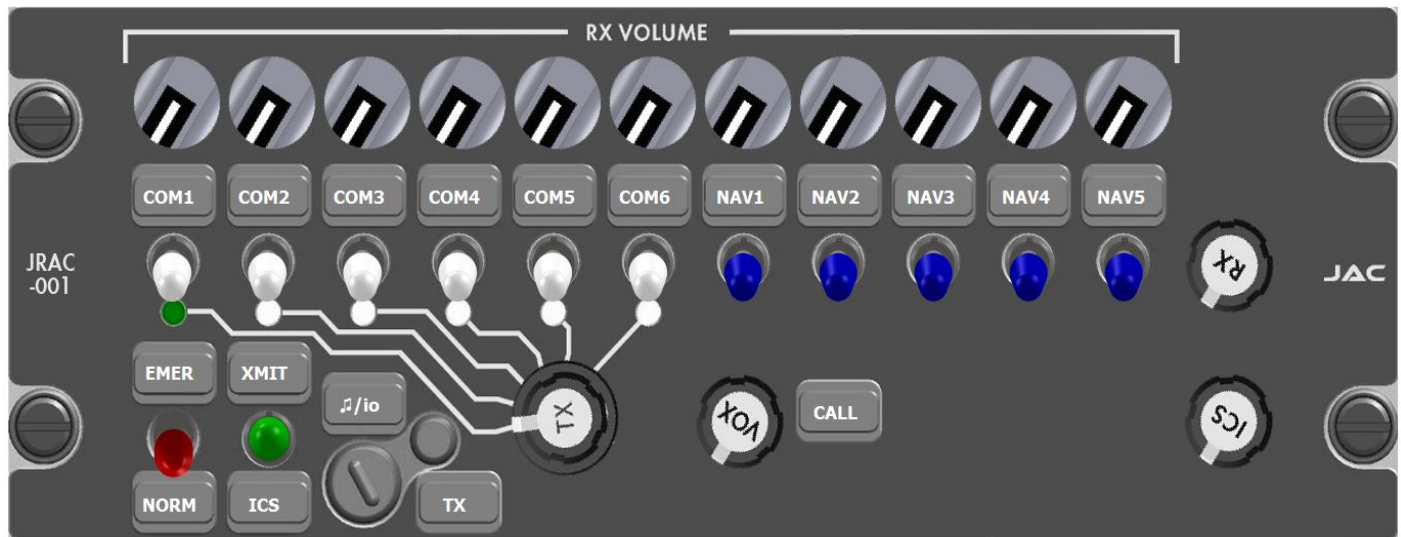

From the Virtual Control Panel it is possible to adjust the switches 'on' and 'off' by clicking on them, and to adjust the rotary controls by 'dragging' them round.

#### 2.6.1.1 Transceiver and Receiver Controls

The COM and NAV controls can be selected ON (up) or OFF (down) by clicking on them. Above each selector switch is an individual rotary volume control which is rotated clockwise (cw) to increase and counterclockwise (ccw) to reduce the volumes.

#### 2.6.1.2 Master Receive Volume Control

The Master Receive Volume Control is a rotary volume control that rotates clockwise to increase and counterclockwise to reduce all the receive volumes simultaneously.

#### 2.6.1.3 Transmit Selection

When the TX control is rotated, the annunciator below the 'selected' legend will turn green (COM 1 shown above).

#### 2.6.1.4 Mode Selection

The mode selection control is a two position switch used to select NORM (normal mode - down) or EMER (emergency mode - up).

#### 2.6.1.5 XMIT/ICS selection

The XMIT/ICS selection control is a two position centre-off that acts as the pilot's 'Press-to-talk' (PTT) button. The unit will transmit on the selected transceiver when the switch is in the 'up' position, and when in the 'down' position, it will transmit on the intercom.



2.6.1.6 XMIT/ICS selection

This is a rotary knob that is used to select the VOX threshold of the unit.

When rotated fully cw, the threshold will be at maximum and VOX ICS operation is disabled and ICS PTT input is required for ICS operation.

When rotated fully ccw, the threshold will be at minimum (almost live).

To adjust the unit for **VOX** (Voice activated) use, the VOX control should be set fully ccw and then slowly rotated cw to the point where no intercom audio can be heard. The VOX control should be adjusted for proper operation according to the ambient noise.

2.6.1.7 ICS Volume control

This is a rotary control used to adjust the volume of all ICS audio to suit the ambient conditions. Rotating the control completely cw gives rated level, and completely ccw reduces the output to minimum level.

2.6.1.8 CALL Annunciator

This annunciator is activated by an external switch.

When enabled, it will illuminate when a ground is applied to the CALL input from another user's audio controller or by a remote 'call' button within the aircraft.

**2.7 Installation Kit**

The kit required to install this unit is not included with the unit.

The installation kit (Part # INST-JRAC) consists of the following:

<b>Quantity</b>	<b>Description</b>	<b>JAC Part #</b>
1	D-Sub 37-pin connector, hood and 37 crimp pins	CON-3420-0037
1	D-Sub 50-pin connector, hood and 50 crimp pins	CON-3420-0050
1	D-Sub 15-pin connector, hood and 15 crimp pins	CON-3420-0015
2	0.625" Inside Diameter, Hardware - Tag Ring	CON-5500-0625
2	Heat Shrink Tubing	WIR-HTSK-1000

2.7.1 Recommended Crimp tools

<b>Connector Type</b>	<b>Hand crimp tool</b>	<b>Positioner</b>	<b>Insertion/extraction tool</b>
Positronic	9507	9502-3	M81969/1-04
Positronic	AFM8 (Daniels)	M22520/2.08 KB-1	

**2.8 Installation Drawings**

The drawings and documents required for Installation can be found in [Appendix A](#) of this manual.

2.8.1 Generation of Custom Drawings

The interconnect and connector maps in Appendix A of this manual are generic drawings based on the standard version of the JRAC-001. However, if a unit has been configured using JAC's ProCS™ software, the software can be used to generate fully customized interconnects and connector maps for use by the installer.



## JRAC-001 Remote Audio Controller

### SECTION 3 – OPERATION

#### 3.1 Introduction

This section contains the operating instructions for the JRAC-001.

The JRAC-001 is a remotely mounted audio controller. The operator controls the functions of the JRAC-001 with a control device, such as a Jupiter Avionics JCPx Control Panel or a Multi-Function Display (MFD), via a serial data bus.

For selection of receivers, transceivers and other controls, refer to the control device manual.

#### 3.2 Normal Mode of Operation

The JRAC-001 is in Normal mode when aircraft electrical power is applied to the unit, Normal Mode has been selected on the control device, and the external EMERGENCY/NORMAL select switch is in the NORMAL position.

##### 3.2.1 Receiving

The control device determines which transceivers and receivers are selected for receive operation. When receive audio is input to the JRAC-001 on a transceiver or receiver that has been selected, the incoming audio is directed to the user's phones unless the user is transmitting and muting of receive audio during transmit has been enabled.

The control device is used to select the receive volume level. When the configuration setting Mute RX Audio is enabled, the receive audio is muted during transmit.

##### 3.2.2 Transmit Operation

The control device determines which transceiver is selected for transmit. When the user's TX PTT is activated, the unit will key the selected transceiver. The user's mic audio is routed to the selected transceiver, sidetone audio is routed to the user's phones, and music is muted for the duration of the transmission.

##### 3.2.3 COM5 PTT Operation



---

**Note:** If the COM5 transceiver has been configured as duplex, it can be used with a cellphone or sat-phone. Check your configuration with the installing agency.

---

If the unit has been configured for cellphone or sat-phone use and COM5 has been selected for transmit, momentarily activating a TX PTT will start COM5 transmitting. A second momentary activation of the same TX PTT or selecting a different Transceiver from the control device will stop COM5 transmitting.

Transmit timeout operation does not operate for COM 5 when its transmit mode is set to duplex.

##### 3.2.4 VOX Operation

The VOX threshold is set from the control device.

A user's MIC audio is routed to the ICS when the MIC audio level exceeds the VOX threshold.

A user's MIC audio is disconnected from the ICS after the MIC audio level falls below the VOX threshold for 0.5 to 2 seconds.



### 3.2.5 Passenger Dropcord Mode Operation

If a passenger dropcord has been selected through ProCS™, the VOX threshold for passengers is set to a minimum level when the VOX is set to maximum.

### 3.2.6 ICS Operation

ICS audio is the sum of all the MIC audio from users with ICS KEY active or with MIC audio level exceeding the VOX Threshold level.

The ICS audio also includes the audio input on the ICS TIE from other audio controllers.

The ICS audio is output on the ICS TIE line and on the phones of each user. The control device determines the ICS volume level.

The ICS audio is muted during transmit (if selected via ProCS – [see section 2.5.3.8](#)).

The ICS audio level at the phones is controlled by the ICS volume control.

### 3.2.7 Music Operation

Music to the phones will be muted by incoming audio (ICS, Receive, Direct or Alert Audio) or if the unit is transmitting. When the incoming audio has ended, the music will gradually return to the previous level.

### 3.2.8 Alert Operation



---

**WARNING:** The internal audio alerts are intended only to supplement, **NOT** replace, airframe alerts such as 'low rotor RPM', 'engine out' or 'decision height alerting'. The alert audio feature is intended for use as a secondary alerting system where another device provides the primary annunciation.

---

At the time of installation/configuration, two alert audio waveforms can be selected. Each alert can have a duration of up to 8 seconds.

If an alert is triggered, the appropriate alert will play continuously in the selected operator headphones until the alert event ceases. The alerts may be muted during transmission, unless transmitting and muting of alert audio during transmit is disabled.



---

**Note:** The ALERT ENABLE input is normally connected to the alert power in the aircraft and is used to disable the alert tones during engine start-up.

---

## 3.3 Emergency Operation Mode

The JRAC-001 is in emergency mode when aircraft electrical power is lost, Emergency Mode has been selected on the control device, or the external EMERGENCY/NORMAL select switch is in the EMERGENCY position.



---

**Note:** During configuration via ProCS, either DIRECT AUDIO 2 or CVR is selected. In Emergency Mode, DIRECT AUDIO 2 will be sent to the Pilot's phones if selected. If CVR is selected, the pilot's phones output will also be directed to the CVR.

---

### 3.3.1 Auto Emergency Mode

If the unit is in emergency mode because power has been lost to the unit, the sum of the COM 1 transceiver, NAV 1 receive, DIRECT AUDIO 1 and DIRECT AUDIO 2 (when configured on) will be routed to the pilot's phones and the CVR. The pilot's microphone and transmit key are connected to the COM 1 transceiver. No other functions in the JRAC-001 will operate when power is lost.



### 3.3.2 Selected Emergency Mode

If Emergency mode has been selected from the control device or from an external emergency/normal switch, and sufficient power is applied to the JRAC-001, the sum of the COM 1 receive, NAV 1 receive, DIRECT AUDIO 1 and DIRECT AUDIO 2 (when configured on) and Alert audio will be routed to the pilot's phones and the CVR. The pilot's microphone and transmit key are connected to the COM 1 transceiver. The pilot is disconnected from the ICS. The COM 1 transceiver and NAV 1 receiver and DIRECT AUDIO 1 are not available to the other users. All other functions of the JRAC-001 will operate.

### 3.3.3 EMER RADIO SELECT

When the EMER MODE SELECT is active, the COM 2 and NAV 2 radios are connected to the PILOT's headphone and microphone instead of the COM 1 and NAV 1 radios.



# Installation and Operating Manual

## Appendix A - Installation Drawings

### A1 Introduction

The drawings necessary for installation and troubleshooting of the JRAC-001 Remote Audio Controller are in this Appendix, as listed below.



**Note:** A fully customized set of Connector Maps and Interconnects can be created using the ProCS software. Refer to the [ProCS™ manual](#) for further information.

### A2 Installation Drawings

DOCUMENT	Rev
<a href="#">JRAC-001 Connector Map</a>	B
<a href="#">JRAC-001 Interconnect</a>	C
<a href="#">JRAC-001 Mechanical Installation</a>	B

# RECEIVE CONNECTOR

**P1**

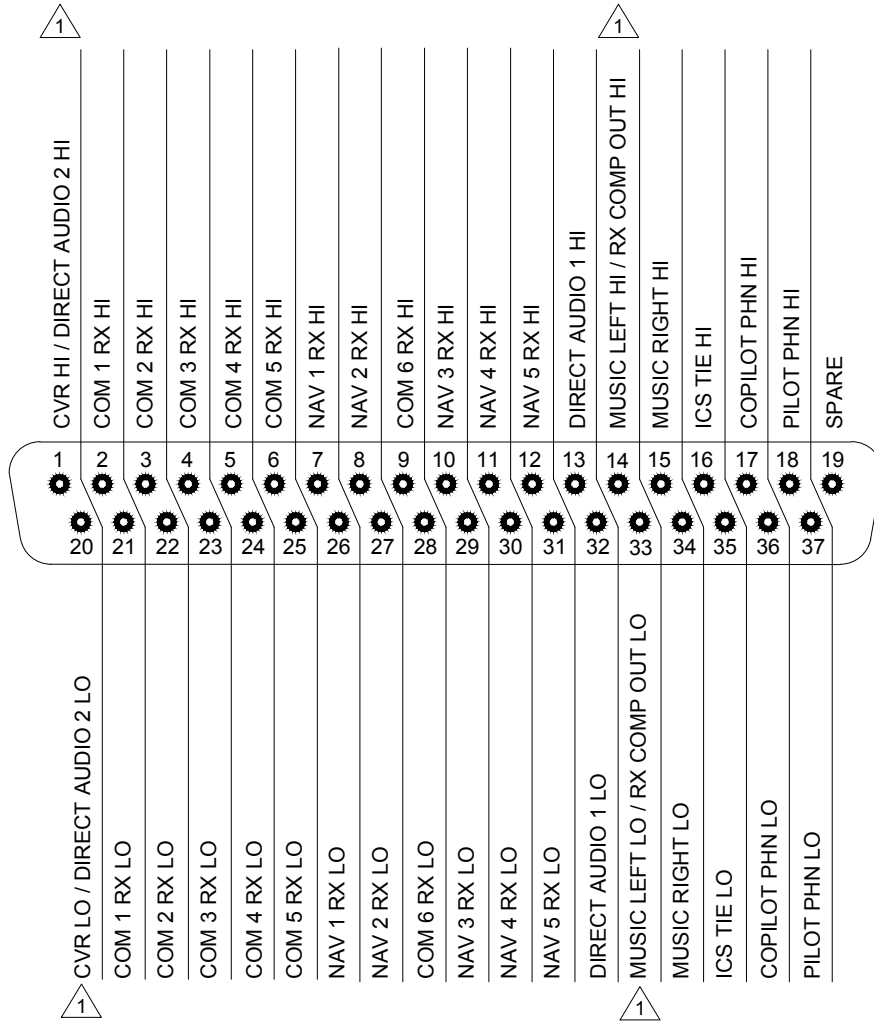

37 PIN FEMALE DMIN  
MATING CONNECTOR



VIEW IS FROM REAR OF MATING CONNECTOR

NOTE:

CONFIGURABLE CONTACT

PREPARED	TAT			
CHECKED				
APPROVED		Remote Audio Controller P1 Connector Map		
CONFIDENTIAL & PROPRIETARY TO JUPITER AVIONICS CORP.		NCAGE CODE L00N3	PART NO. JRAC-001	SHEET 1/3
		DOC NO. JRAC-001 Connector Map Rev B.dwg		

# TRANSMIT CONNECTOR

P2

50 PIN FEMALE DMIN  
MATING CONNECTOR

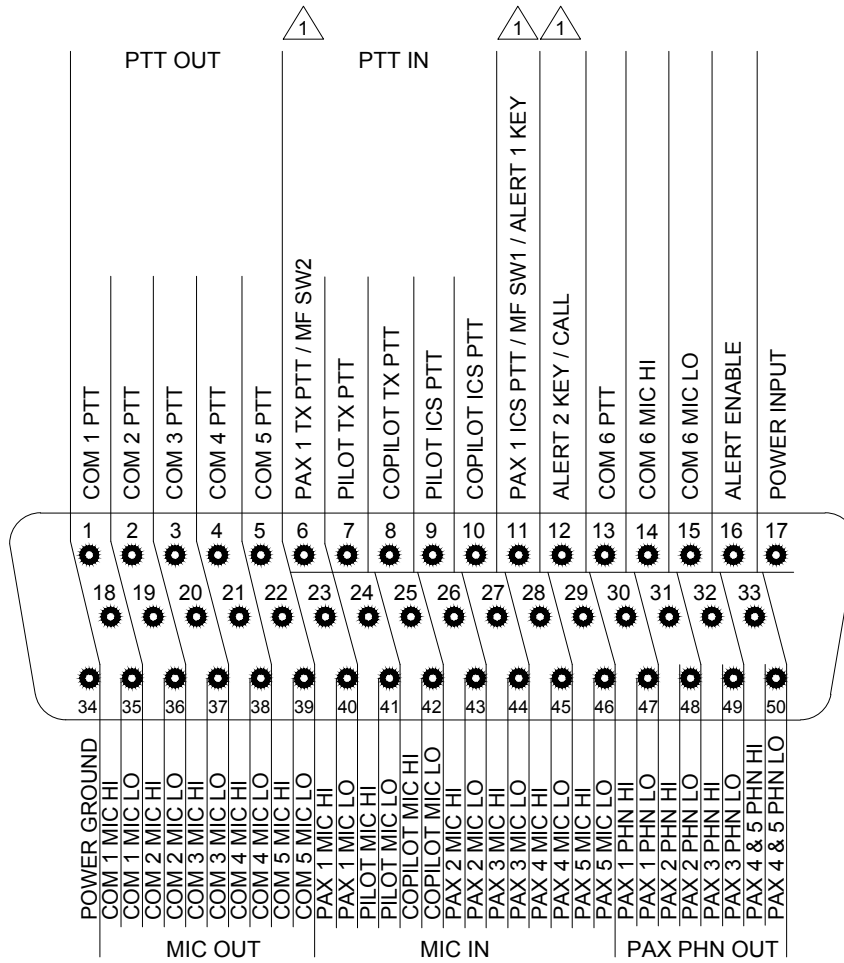

VIEW IS FROM REAR OF MATING CONNECTOR

PREPARED	TAT	<b>JUPITER AVIONICS</b> CORPORATION		
CHECKED				
APPROVED		NCAGE CODE L00N3	PART NO. JRAC-001	SHEET 2/3
CONFIDENTIAL & PROPRIETARY TO JUPITER AVIONICS CORP.		DOC NO. JRAC-001 Connector Map Rev B.dwg		

# CONFIGURATION CONNECTOR

**P4**

ACCEPTS THE FOLLOWING PLUG FORMATS

JA99 CONFIGURATION CABLE  
4 POLE MALE 3.5MM STEREO

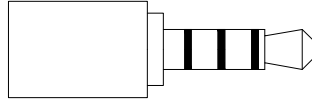

MATING PLUG NAMES

TIP: TX DATA  
1ST RING: RX DATA  
2ND RING: GROUND  
3RD RING: CONFIG AUDIO

JRAC SIGNAL NAMES



CONFIG DATA TO JRAC  
CONFIG DATA FROM JRAC  
CONFIG COMMON  
MODE SELECT / CONFIG AUDIO

# CONTROL CONNECTOR

**P3**

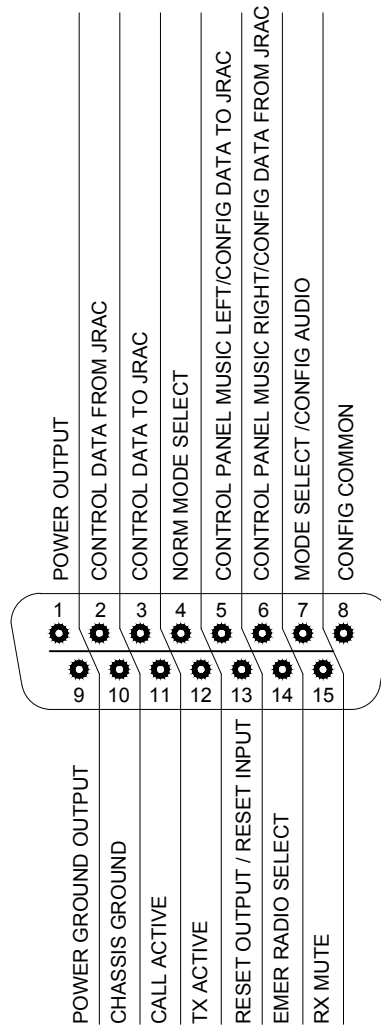
15 PIN FEMALE DMIN  
MATING CONNECTOR



PREPARED	TAT			
CHECKED				
APPROVED		Remote Audio Controller P3 and P4 Connector Map		
CONFIDENTIAL & PROPRIETARY TO JUPITER AVIONICS CORP.		NCAGE CODE L00N3	PART NO. JRAC-001	SHEET 3/3
		DOC NO. JRAC-001 Connector Map Rev B.dwg		

JRAC-001 INTERCONNECT WIRING NOTES



NOTES

1. ALL WIRE SIZE SHOULD BE 24 AWG MIN UNLESS OTHERWISE SPECIFIED. UNSHIELDED WIRE SHOULD BE SELECTED PER FAA AC43.13-1B CHANGE 1 PARA 11-76 TO 11-78. WIRE TYPES SHOULD BE IN ACCORDANCE WITH MIL-W-22759 AS DESCRIBED IN FAA AC43.13-1B CHANGE 1 PARA 11-85 AND 11-86 AND LISTED IN TABLE 11-11 OR 11-12. ALL SHIELDED CABLE SHOULD BE IN ACCORDANCE WITH MIL-DTL-27500 (REVISION H OR LATER).
2. CONNECTION TO AIRFRAME GROUND SHOULD BE MADE WITH 20 AWG WIRE. LENGTH NOT TO EXCEED 3 FT (0.91 M).
3. CABLE SHIELDS AT THE CONNECTOR PINS SHOULD BE TERMINATED TO AIRFRAME GROUND USING A TAG RING P/N: MS27741-5 OR EQUIVALENT.
4. CONNECTOR PIN HAS MORE THAN ONE FUNCTION. SEE THE OPTIONS SECTION OF THIS DRAWING FOR ALTERNATIVE INTERCONNECT WIRING.
5. GROUND PIN FOR NORMAL OPERATION. LEAVE UNCONNECTED FOR EMERGENCY OPERATION.
6. RESET OUTPUT PIN OUTPUTS A MOMENTARY GROUND WHEN CONTROL DATA TO JRAC IS NOT VALID. OUTPUT IS OPEN COLLECTOR.
7. TX ACTIVE PIN OUTPUTS A GROUND WHEN ANY USER TX PTT IS ACTIVE. OUTPUT IS OPEN COLLECTOR.
8. LEAVE PIN UNCONNECTED FOR COM 1 AND NAV 1 OPERATION IN EMERGENCY MODE. GROUND PIN FOR COM 2 AND NAV 2 OPERATION IN EMERGENCY MODE.
9. GROUND PIN TO MUTE ALL RECEIVE AUDIO EXCEPT FROM THE TRANSCEIVER SELECTED TO TRANSMIT.
10. CALL ACTIVE PIN OUTPUTS A GROUND WHEN THE CALL PIN IS ACTIVATED. OUTPUT IS OPEN COLLECTOR.
11. MOMENTARILY GROUND PIN TO RESET REMOTE AUDIO CONTROLLER

CONNECTOR PIN LEGENDS

LEGEND

- SPARE                      INTERNAL CIRCUITS MAY EXIST AND MAY BE ACTIVATED FOR FUTURE USE. NO EXTERNAL WIRE CONNECTION.
- N/C                         NO CONNECTION



PREPARED	TAT			
CHECKED				
APPROVED		Remote Audio Controller Interconnect Notes		
CONFIDENTIAL & PROPRIETARY TO JUPITER AVIONICS CORP.		NCAGE CODE L00N3	PART NO. JRAC-001	SHEET 1/6
		DOC NO. JRAC-001 Interconnect Rev C.dwg		

JRAC-001  
RECEIVE CONNECTOR

J1

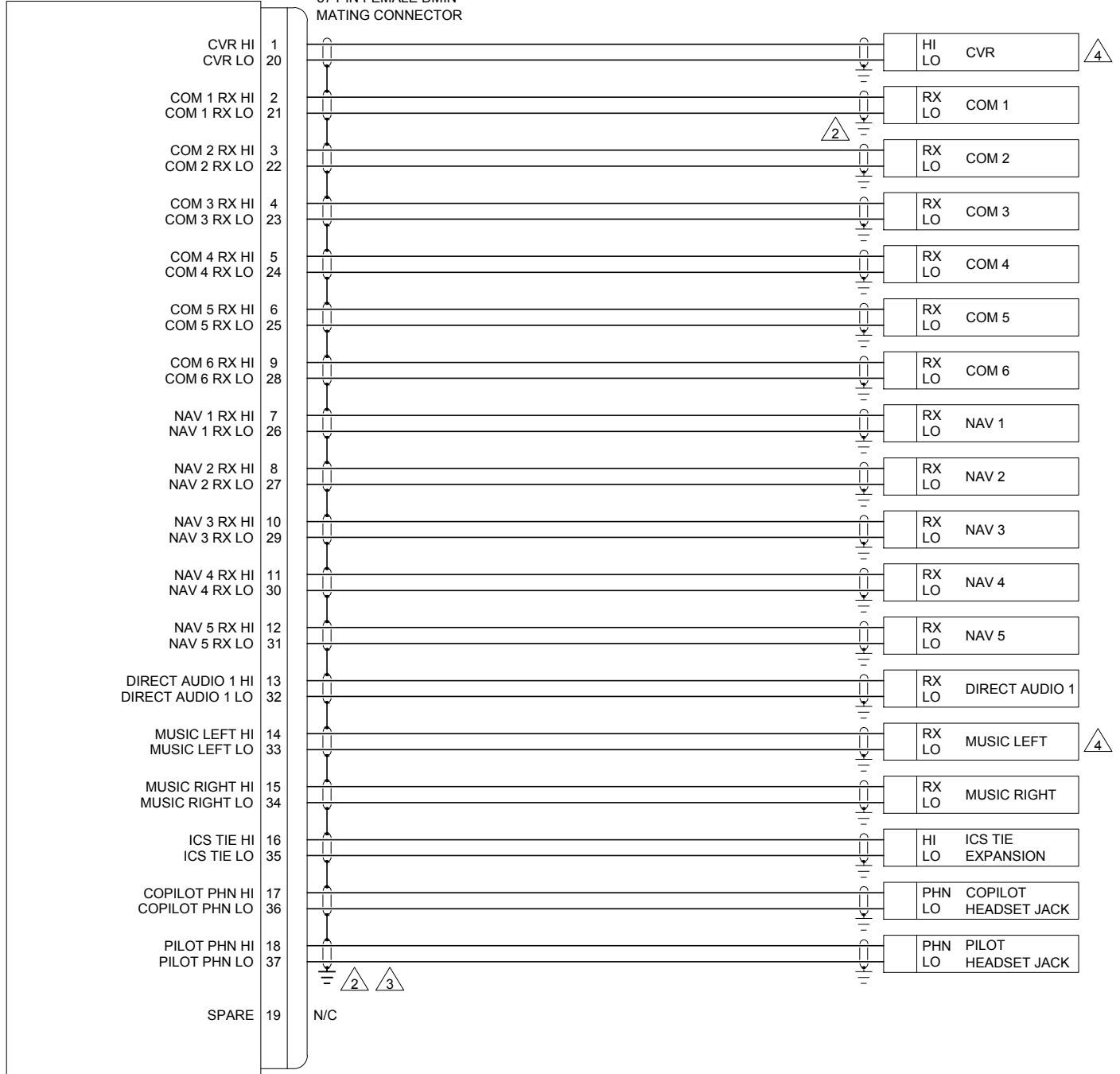
P1  
37 PIN FEMALE DMIN  
MATING CONNECTOR







PREPARED	TAT			
CHECKED				
APPROVED		Remote Audio Controller J1 Interconnect		SHEET
CONFIDENTIAL & PROPRIETARY TO JUPITER AVIONICS CORP.		NCAGE CODE L00N3	PART NO. JRAC-001	2/6
		DOC NO. JRAC-001 Interconnect Rev C.dwg		

JRAC-001  
TRANSMIT CONNECTOR

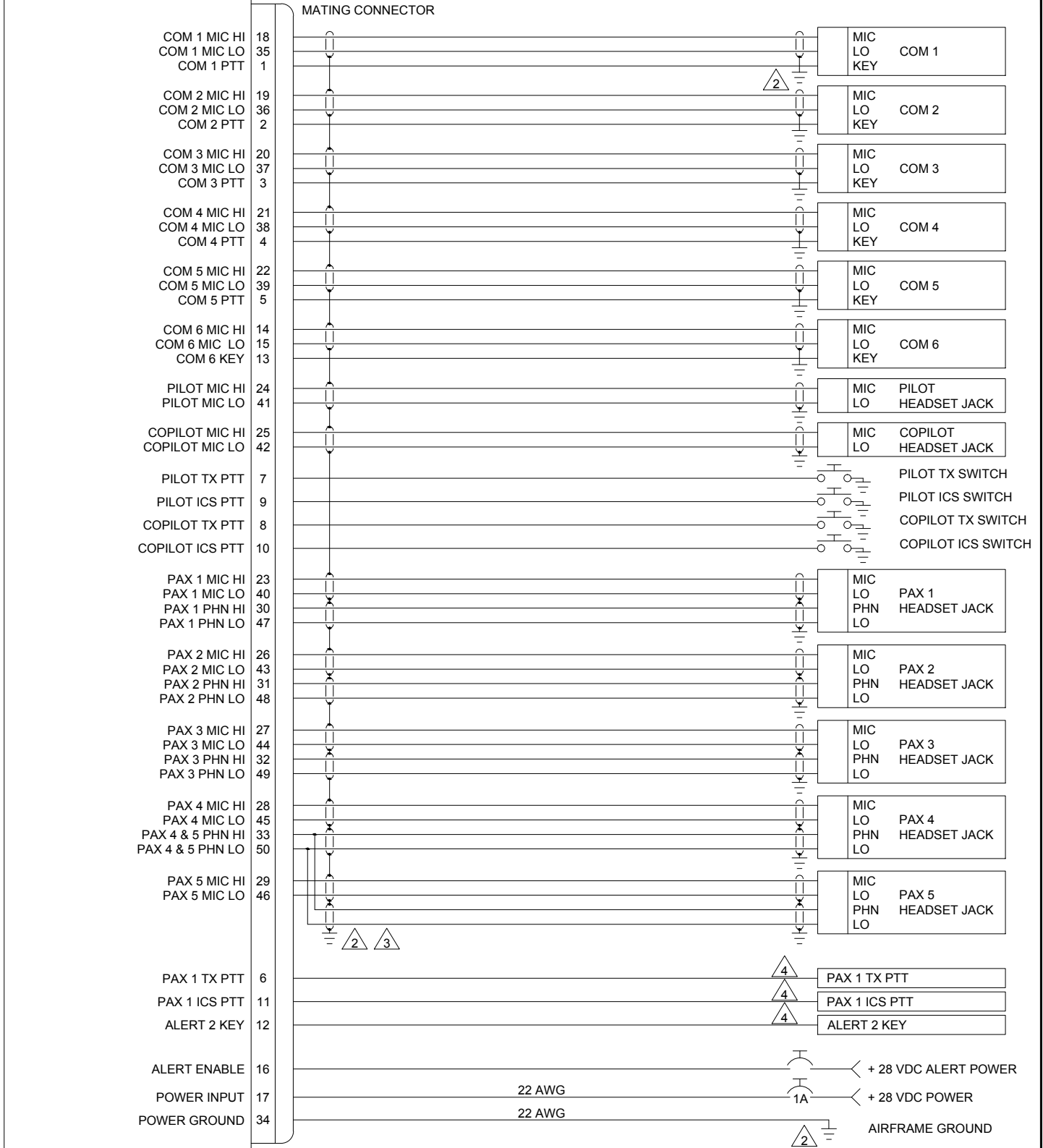
J2

P2  
50 PIN FEMALE DMIN  
MATING CONNECTOR



PREPARED	TAT			
CHECKED				
APPROVED		Remote Audio Controller J2 Interconnect		
CONFIDENTIAL & PROPRIETARY TO JUPITER AVIONICS CORP.		NCAGE CODE L00N3	PART NO. JRAC-001	SHEET 3/6
DOC NO. JRAC-001 Interconnect Rev C.dwg				

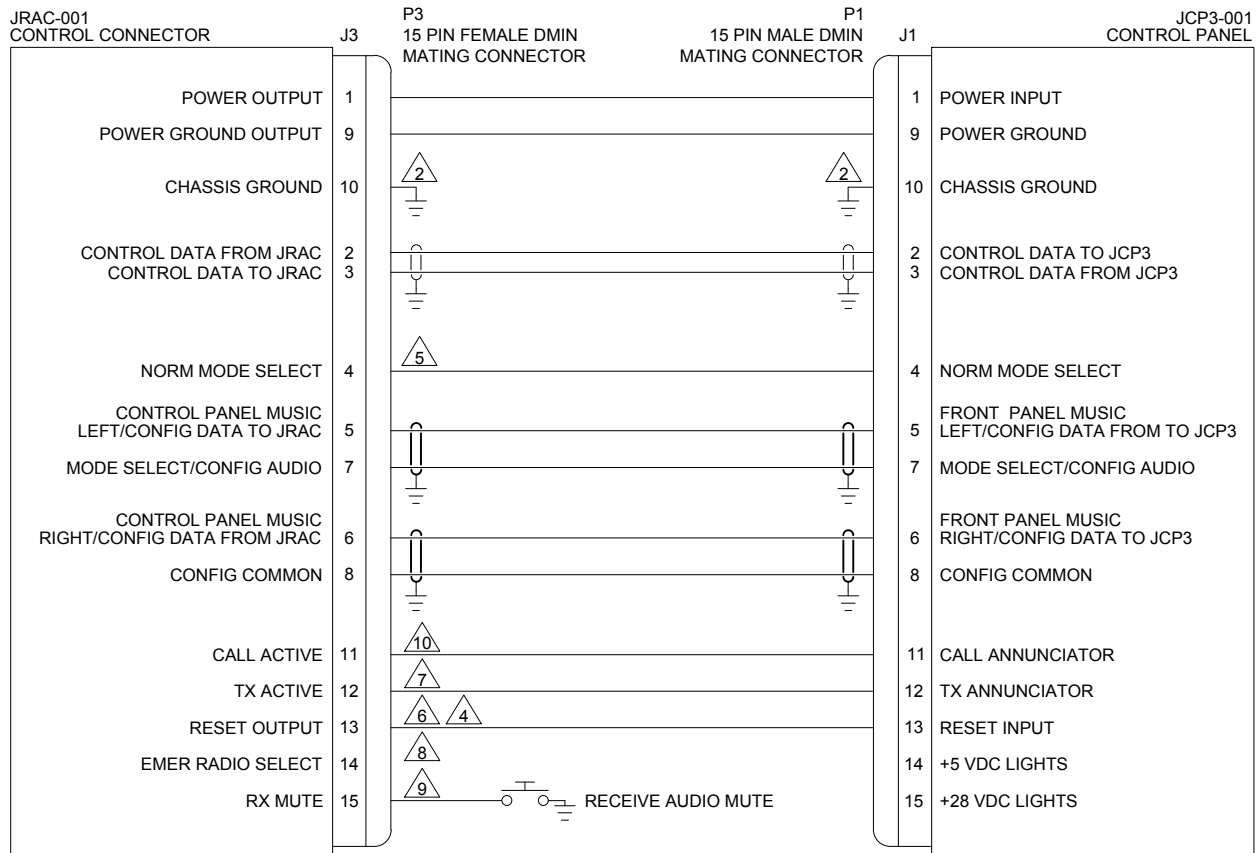



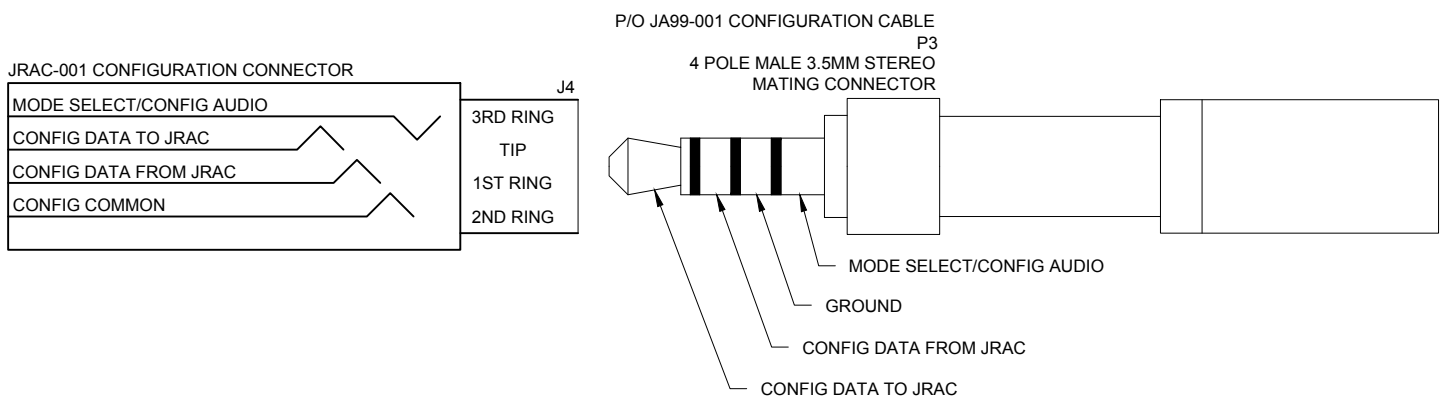

CONFIGURATION FROM ProCS APPLICATION VIA JA99-001 CABLE

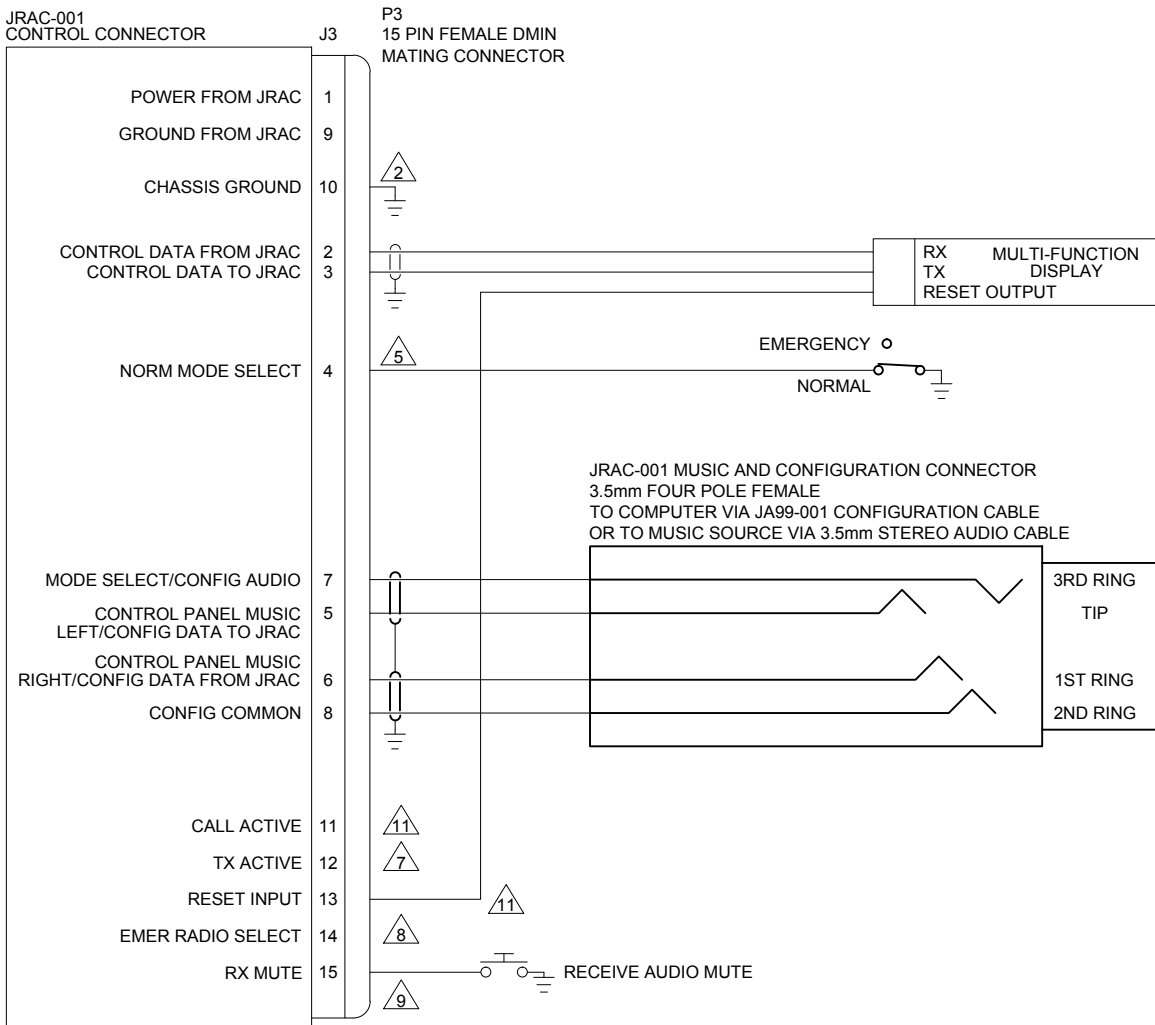

PREPARED	TAT			
CHECKED				
APPROVED		Remote Audio Controller J3 and J4 Interconnect		
CONFIDENTIAL & PROPRIETARY TO JUPITER AVIONICS CORP.		NCAGE CODE L00N3	PART NO. JRAC-001	SHEET 4/6
		DOC NO. JRAC-001 Interconnect Rev C.dwg		

**OPTION: MULTI-FUNCTION DISPLAY CONTROL**



PREPARED	TAT			
CHECKED				
APPROVED		Remote Audio Controller Interconnect Options		SHEET
CONFIDENTIAL & PROPRIETARY TO JUPITER AVIONICS CORP.		NCAGE CODE	PART NO.	5/6
		L00N3	JRAC-001	
		DOC NO. JRAC-001 Interconnect Rev C.dwg		

OPTION: DIRECT AUDIO 2 IN

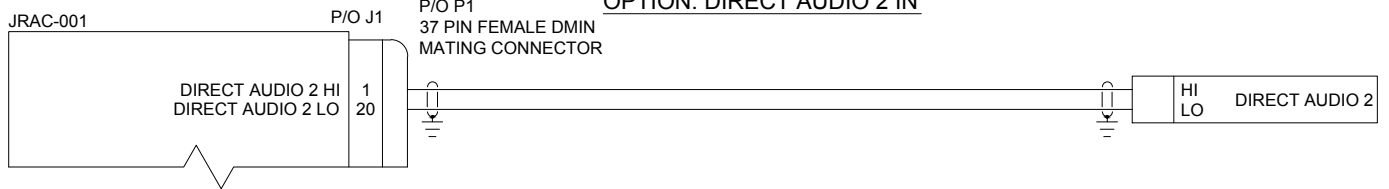

OPTION: RX COMPOSITE OUT

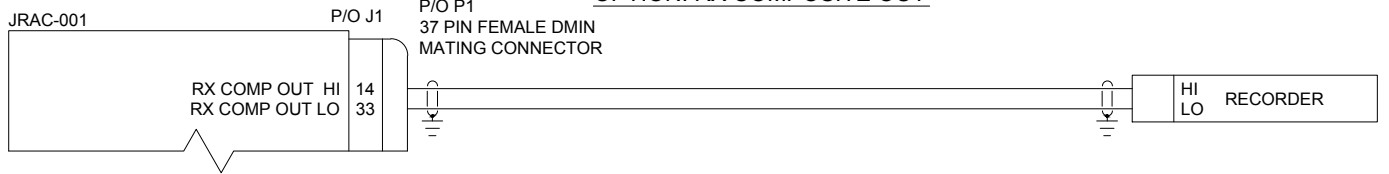

OPTION: MULTIPLE AUDIO CONTROLLER

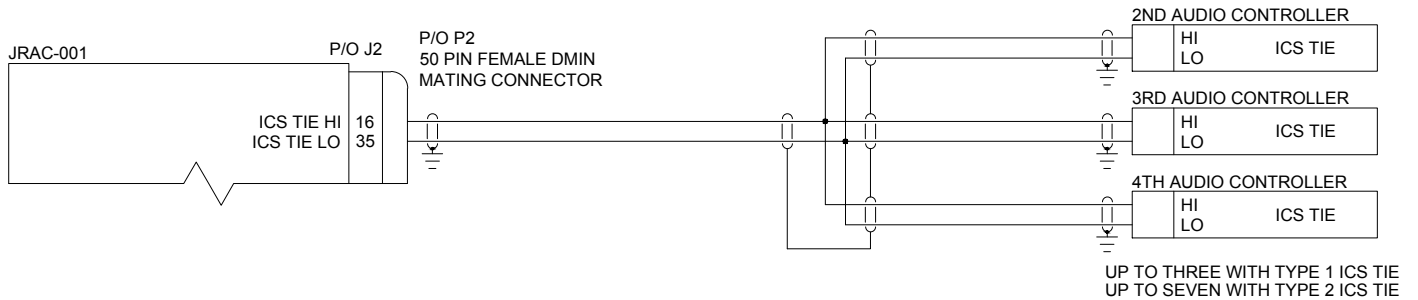

OPTION: CALL INPUT

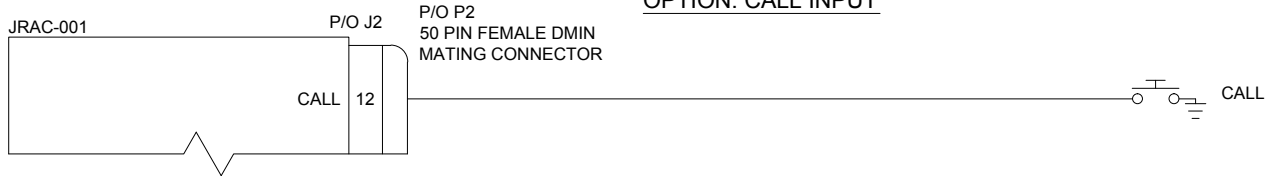

OPTION: CONFIGURABLE SWITCH INPUTS (ALERT 1 KEY)

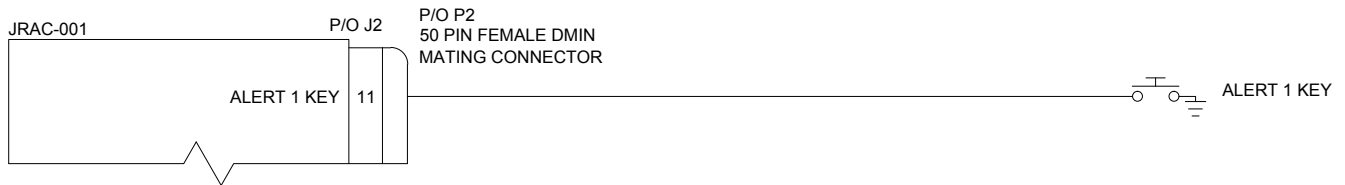

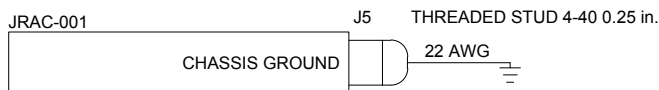

OPTION: CHASSIS GROUND

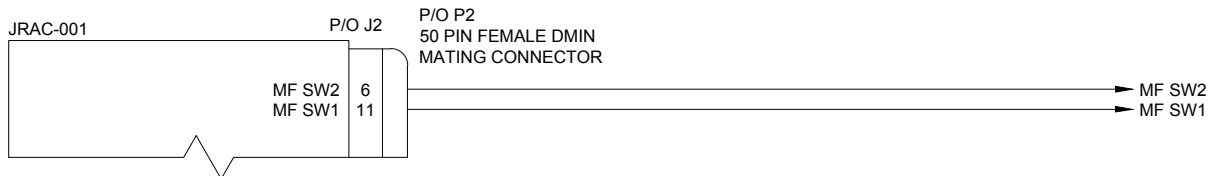

OPTION: MULTI-FUNCTION SWITCH OUTPUTS



PREPARED	TAT			
CHECKED				
APPROVED		Remote Audio Controller Interconnect Options		SHEET
CONFIDENTIAL & PROPRIETARY TO JUPITER AVIONICS CORP.		NCAGE CODE	PART NO.	6/6
		L00N3	JRAC-001	
DOC NO.		JRAC-001 Interconnect Rev C.dwg		

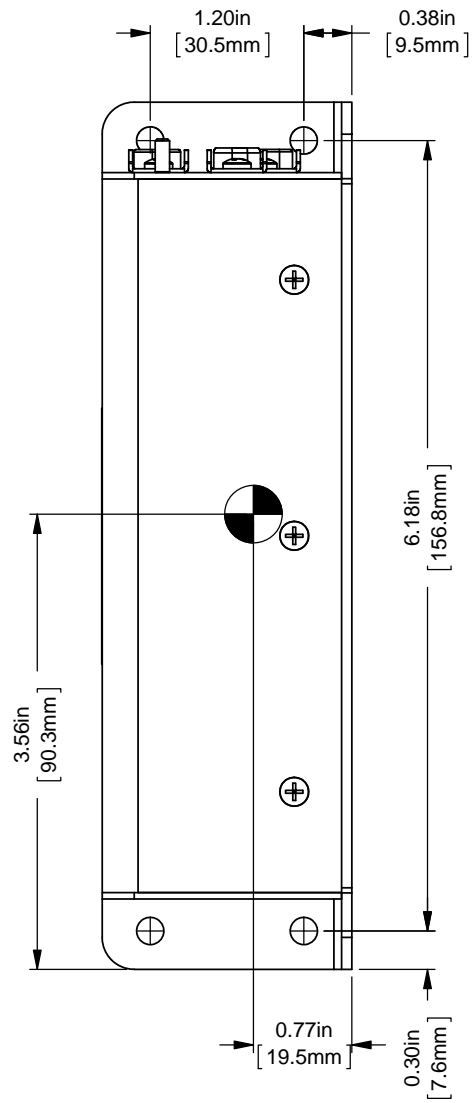
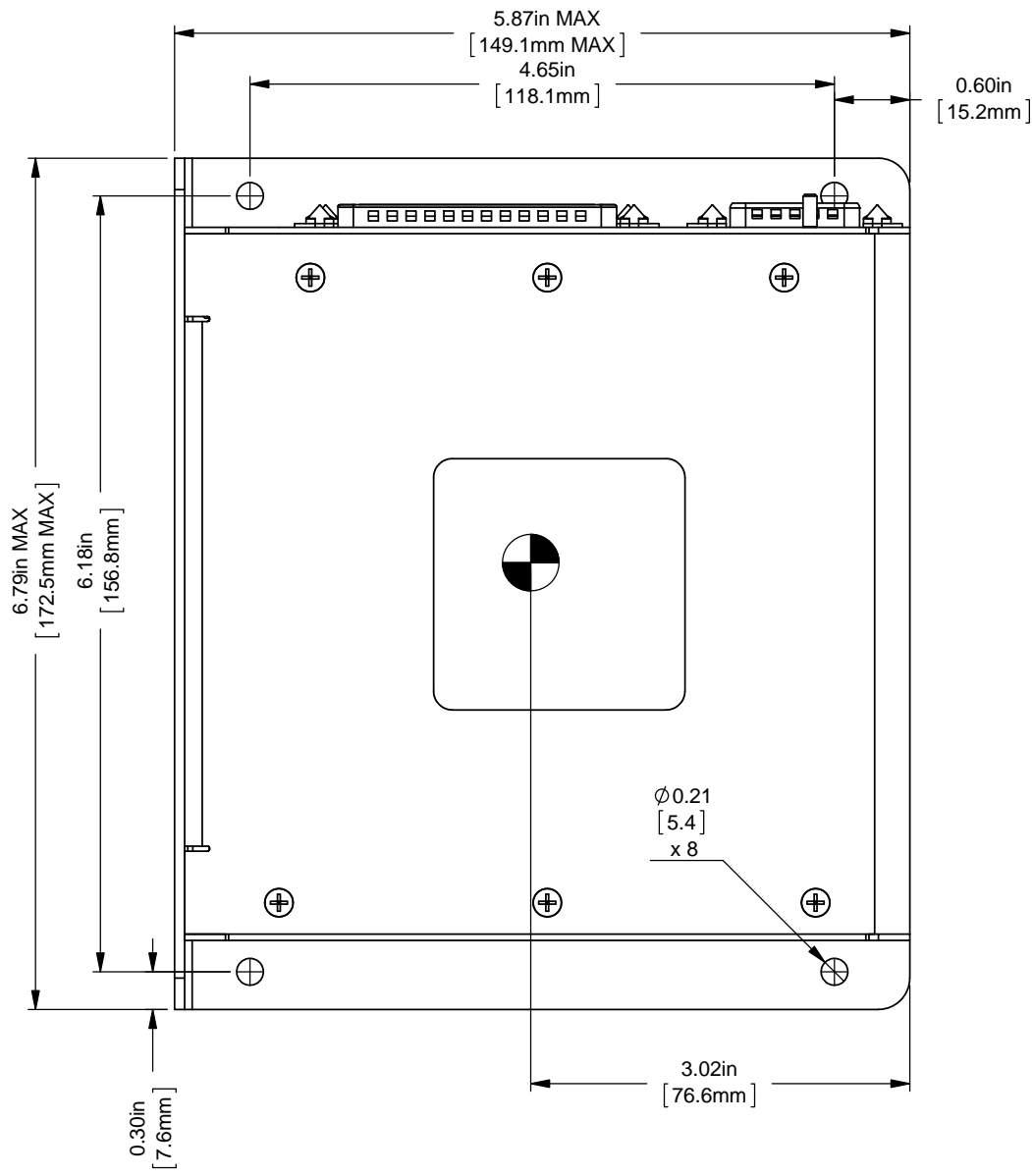
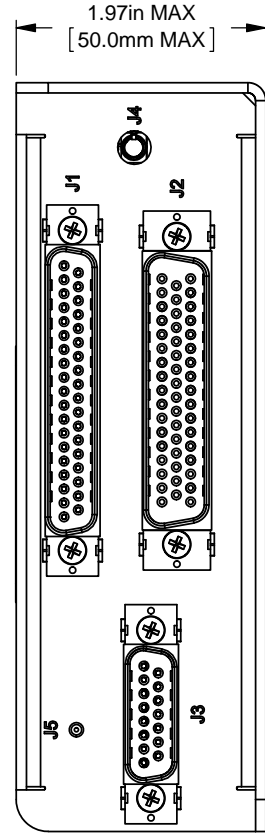
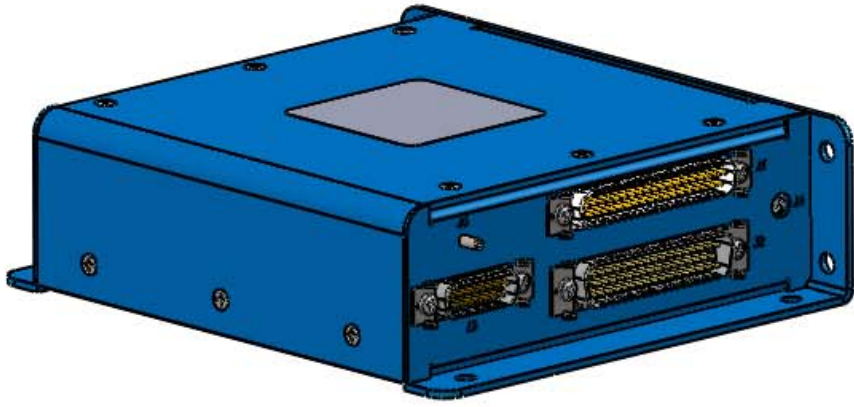

☉ CENTER OF GRAVITY  
±0.03in [0.8mm]

WEIGHT: 1.94 lbs [0.88 kg] MAX.

UNLESS OTHERWISE SPECIFIED  
DIMENSIONS ARE IN INCHES  
ANGLES ARE IN DEGREES  
TOLERANCES:  
1 DEC PLACE: ± 0.1  
2 DEC PLACE: ± 0.01  
3 DEC PLACE: ± 0.005  
ANGLES: ± 0.5 DEG

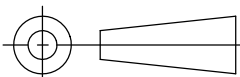

MATERIAL: N/A  
FINISH: N/A

PREPARED

TAT

CHECKED

JAC  
01-13-15  
DS

APPROVED

JAC  
01-13-15  
KDV

CONFIDENTIAL & PROPRIETARY  
TO JUPITER AVIONICS CORP.  
DRAWING NOT TO SCALE



**JUPITER AVIONICS**  
CORPORATION

TITLE

Remote Audio Controller

NCAGE CODE  
L00N3

PART NO.  
JRAC-001

SHEET  
1/1

DOC. NO.  
JRAC-001 Mechanical Installation Rev B.SLDDRW



# **Installation and Operating Manual**

## **Appendix B - Certification Documents**



## **B1 Airworthiness Approval**

Airworthiness approval of the JRAC-001 may require completion of a TCCA Major Modification Report per CAR STD (AWM) 571 Appendix L or a FAA Form 337. The sample wording for a description of the work is provided to assist the Installing Agency in preparing Instructions for Continued Airworthiness (ICA) when replacing an existing audio panel with a Jupiter Avionics JRAC-001 Remote Audio Controller. This sample may be modified appropriately for new installations. It is the installer's responsibility to determine the applicability of the method used. Installations performed outside Canada and the USA must follow the applicable aviation authority's regulations.

### **Sample Wording:**

Removed the existing [model] audio controller and replaced with a Jupiter Avionics JRAC-001 Remote Audio Controller in [aircraft location].

Installed in accordance with the JRAC-001 Installation Manual, Revision [ ], and AC 43.13-2, Chapters 2, and 3.

The JRAC-001 interfaces with existing aircraft radios per the Installation Manual instructions.

The JRAC-001 Installation Manual provides detailed installation instructions and wiring diagrams (Section 2, and Appendices A and B).

Power is supplied to the JRAC-001 through an existing [ ]-Amp circuit breaker that was previously used by the original audio panel. The net electrical load is unchanged.

Aircraft equipment list, weights and balance amended. Compass compensation checked and found to conform to applicable regulations.

## **B2 Instructions for Continued Airworthiness**

Maintenance of the JRAC-001 Remote Audio Controller is "on condition" only. Refer to the JRAC-001 Maintenance Manual. Periodic maintenance of the JRAC-001 is not required.

The following sample Instructions for Continued Airworthiness (ICA) provides assistance in preparing ICA for the Jupiter Avionics JRAC-001 unit installation as part of a Type Certificate (TC) or Supplemental Type Certificate (STC) project to comply with CAR STD (AWM) 523/527/525/529.1529 or FAR 23/25/27/29.1529 "Instructions for Continued Airworthiness".

Items that may vary by aircraft make and model are shown in brackets ("[ ]") and should be filled in as appropriate. Some of the checklist items do not apply, in which case they should be marked "N/A" (Not Applicable).

### **Instructions for Continued Airworthiness, Jupiter Avionics JRAC-001 Remote Audio Controller in an [Aircraft Make and Model]**

#### **1. Introduction**

[Aircraft that has been altered: Registration number, Make, Model and Serial Number]

**Content, Scope, Purpose and Arrangement:** This document identifies the Instructions for Continued Airworthiness for a Jupiter Avionics JRAC-001 installed in an [aircraft make and model].

**Applicability:** Applies to a Jupiter Avionics JRAC-001 installed in an [aircraft make and model].

**Definitions/Abbreviations:** None, N/A.

**Precautions:** None, N/A.

**Units of Measurement:** None, N/A.

**Referenced Publications:** JRAC-001 Installation and Operating Manual  
JRAC-001 Maintenance Manual  
STC/TC # [applicable STC/TC number for the specific aircraft installation]

**Distribution:** This document should be a permanent aircraft record.



## **2. Description of the System/Alteration**

Jupiter Avionics JRAC-001 Remote Audio Controller with interface to external transceivers and [include other equipment/systems as appropriate]. Refer to Appendix A of this manual for interconnect information. Refer to aircraft manufacturer approved interconnect for actual installation.

## **3. Control, Operation Information**

Refer to section 3 of this manual or to the Jupiter Avionics JRAC-001 Operating Manual.

## **4. Servicing Information**

N/A

## **5. Maintenance Instructions**

Maintenance of the JRAC-001 is 'on condition' only. Periodic maintenance is not required. Refer to the JRAC-001 Maintenance Manual.

## **6. Troubleshooting Information**

Refer to the JRAC-001 Maintenance Manual.

## **7. Removal and Replacement Information**

Refer to Section 2 of this manual - the JRAC-001 Installation and Operating Manual. If the unit is removed and reinstalled, a functional check of the equipment should be conducted.

## **8. Diagrams**

Refer to Appendix A of this manual - the JRAC-001 Installation and Operating Manual - for installation drawings and interconnect examples.

## **9. Special Inspection Requirements**

N/A

## **10. Application of Protective Treatments**

N/A

## **11. Data: Relative to Structural Fasteners**

JRAC-001 and appropriate mounting hardware installation, removal and replacement should be in accordance with applicable provisions of AC 43.13-1B and AC 43.13-2A.

## **12. Special Tools**

N/A

## **13. This Section is for Commuter Category Aircraft Only**

A. **Electrical loads:** Refer to Section 1 of the JRAC-001 Installation and Operating Manual.

B. **Methods of balancing flight controls:** N/A.

C. **Identification of primary and secondary structures:** N/A.

D. **Special repair methods applicable to the airplane:** N/A.

## **14. Overhaul Period**

No additional overhaul time limitations.

## **15. Airworthiness Limitation Section**

N/A