

SPA-400 TSO INSTALLATION AND OPERATING INSTRUCTIONS

The Sigtronics' SPA-400 is a voice actuated intercom with "transmit through the aircraft radio capability" using your push-to-talk switch. Three controls are provided:

Power Switch — Turns unit on and off.

Volume Control — Controls the intercom volume.

Squelch Control — Allows the setting of voice actuated (VOX) operation of the intercom for variations in background noise levels and differences in headset microphones.

OPERATING INSTRUCTIONS

I. INTERCOM MODE

- A. Put on headset/s and position the boom mic close to the mouth, as is the practice with a hand-held mic. Voice clarity is best when mic is at one side of the mouth and 1/4" from the lips.
- B. Set audio panel to "Headphone" position, if applicable.
- C. Turn power "on" and set Volume Control to a low level. (1/4th to 1/3rd open for best signal to noise ratio).
- D. To adjust the intercom SQuelch for voice activated operation (VOX), it is helpful to have some background noise present. Turn intercom SQuelch control all the way counter-clockwise. Now, without speaking, rotate the SQuelch control clockwise until you hear the background noise in your headset. Next, rotate it counter-clockwise a small amount and wait (approximately 1 second) until the background noise disappears. Finally, make small adjustments until your voice triggers the unit at comfortable speaking levels. This procedure is necessary because the squelch is a "Fast-on, Slow-off" system.

Once set, the intercom stays silent until someone speaks in their headset microphone (mic). Then it instantly turns on and relays the conversation. After about a second of no conversation, the intercom goes silent again.

Minor readjustment of the SQuelch may be necessary if the background noise level changes significantly (such as from taxi to take-off power conditions).

- II. **RADIO TRANSMIT MODE** — Transmitting from both pilot and co-pilot positions is possible on a one-at-a-time basis. The transmitting mic

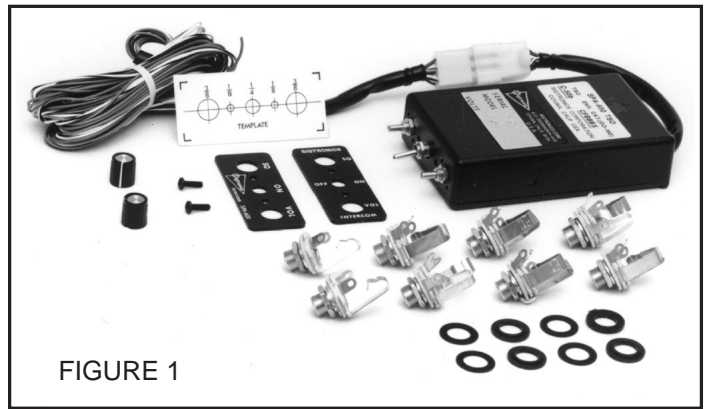

FIGURE 1

disables all other mics. When you are ready to talk to ATC, depress the transmit switch on your yoke and your voice is automatically transmitted via the aircraft radio. (You will hear your own voice when transmitting via the aircraft radio side-tone return. If the radio does not have side-tone, then you will not hear your voice). (A minor modification to the intercom will enable it to simulate side-tone).

- III. **RADIO MONITORING** — Radio monitoring is automatic. The radio monitor circuit is always active; even with intercom power switch "off".
- IV. **SOLO FLIGHTS** — Since the intercom is not needed during solo flights, it may be turned off. The pilot will still hear the aircraft radio, since this circuit is always active, and the pilot may transmit to ATC via his push-to-talk switch. (Co-pilot position cannot transmit when the intercom is off).
- V. **BACK-UP** — If a problem is suspected in the intercom, simply turn it off. You will still receive the aircraft radio and will be able to transmit from the pilot's position. The hand mic may also be used, however, the intercom should be turned off and you should unplug your boom mic from the mic jack. (Leave headphone plugged in for radio reception).

CHASSIS INSTALLATION

The Sigtronics' SPA-400 has been designed to mount either horizontally or vertically in your aircraft panel. All necessary mounting hardware has been supplied for a 4-way installation. (A round faceplate is also available from Sigtronics to fit a 2 1/4" round instrument hole.)

HARDWARE SUPPLIED

Four Headphone Output Jacks- Accept standard .250" aircraft headphone plugs.

Four Microphone Input Jacks- Accept standard .206" aircraft microphone plugs (i.e. carbon or amplified dynamic). (U93 plug compatible jacks can be used in place of the jacks provided).

Mic Jack Insulating Washers: 4 shoulder and 4 flat.

Intercom Panel: Lettered on both sides.

Control Knobs (2), Switch Nut (1), 4-40 Screws (2)

Template: Hole size pattern for drilling aircraft panel.

Aircraft/Intercom interface cable (4 feet long)

The location selected requires a minimum front panel area of 2 1/2" by 1 1/16". Depth required behind panel is 4 3/16" plus cable access.

Caution: Move aircraft flight controls through limits of travel while observing selected area to make sure rear of intercom and cable will not interfere with aircraft control components.

PANEL PREPARATION:

1. Position adhesive template on aircraft panel in selected area.
2. Center punch each hole at cross lines. (The five holes are in straight line and equally spaced 0.4" apart).
3. Drill 1/8" pilot hole all five places.
4. Enlarge holes to 1/4" and 3/8" per template.

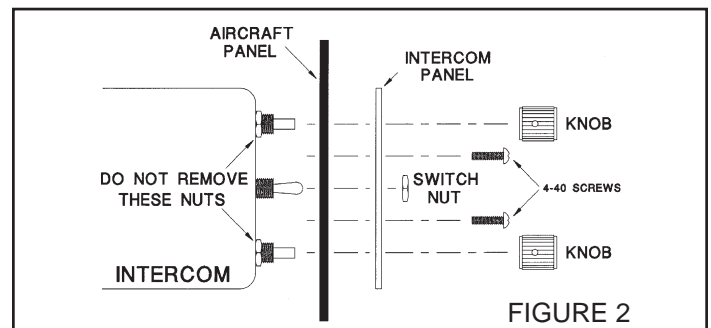

FIGURE 2

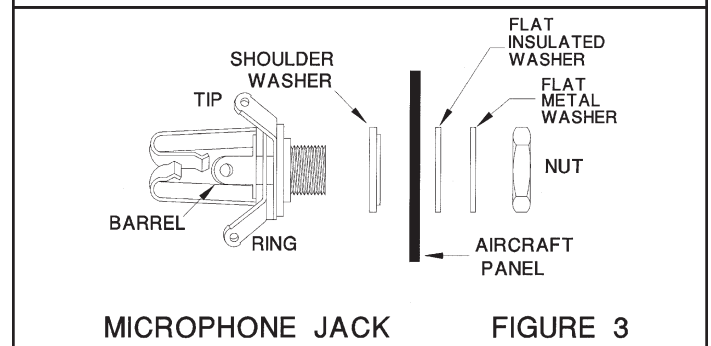

FIGURE 3

MOUNTING CHASSIS: See Figure 2.

1. Remove nut from the intercom ON-OFF switch bushing.
2. Remove knobs from Volume and Squelch controls. NOTE: DO NOT REMOVE nuts from Volume and Squelch control potentiometers.
3. Remove two 4-40 panel screws and remove panel from intercom chassis.
4. Insert intercom from rear of aircraft panel with appropriate arrow pointing upwards.

(continued)



PHONE (909) 305-9399

949 N. Cataract Ave. #D, San Dimas, CA 91773

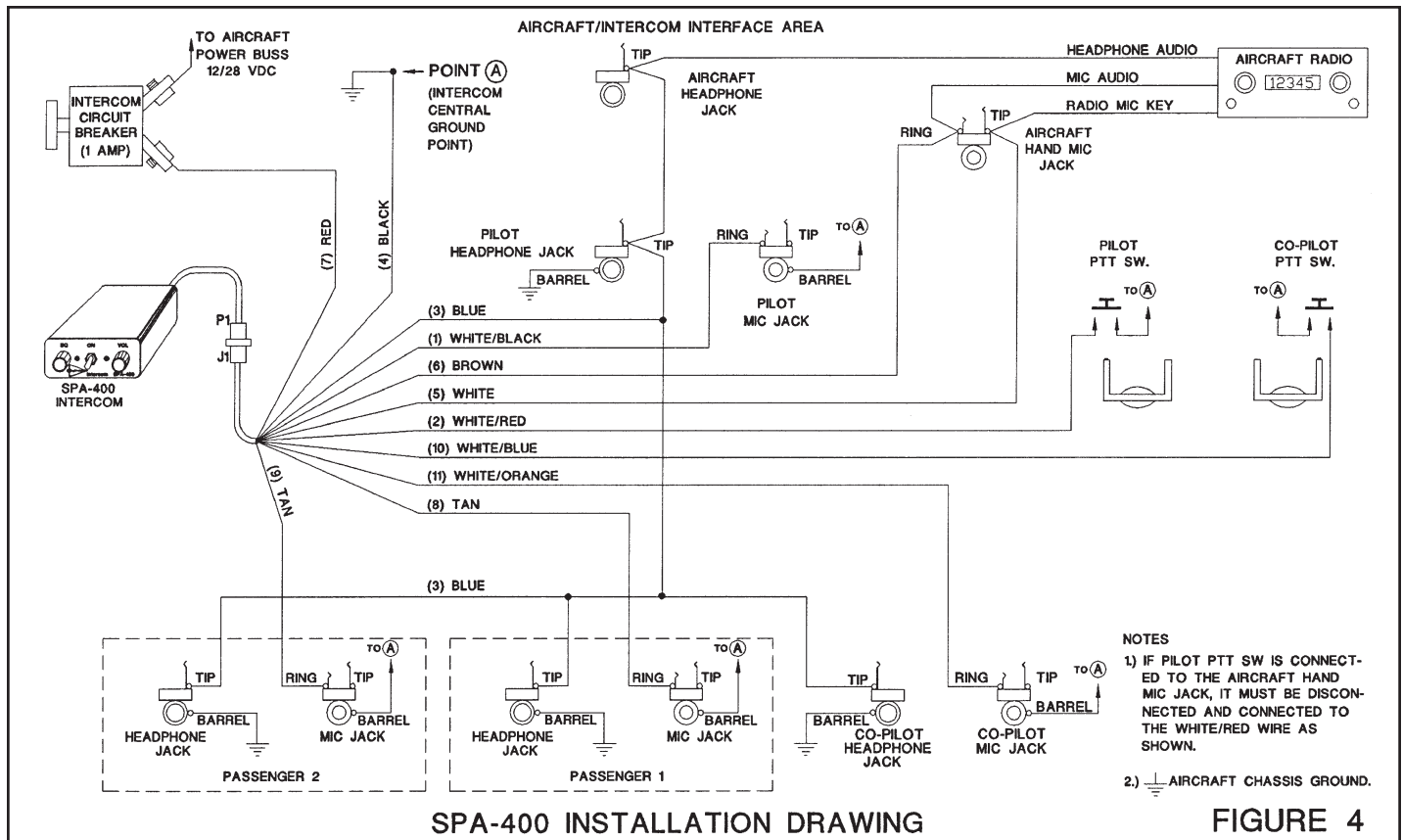

MOUNTING CHASSIS (continued)

6. Select two 4-40 screws through holes in intercom panel. Tighten ON-OFF switch nut.
7. Install knobs on Volume (VOL) and Squelch (SQ) control shafts using .050" Allen wrench.

MOUNTING HEADPHONE AND MICROPHONE JACKS:

1. Select mounting areas. (One mic and one headphone jack for each headset). Again, make sure the jacks will not interfere with aircraft control components.
2. Drill 3/8" diameter holes for headphone jacks and install.
3. Drill 1/2" diameter holes for mic jacks and install with insulating washers supplied. (See Figure 3).

WIRING INSTRUCTIONS

Connections should be made as shown in Figure 4 and indicated in Table 1

*A. White/red (pilot push-to-talk) must correspond with white/black (pilot mic input) as shown.

*B. The blue wire from Pin 3 must be connected to the aircraft radio headphone output- NOT the speaker output.

*C. Connect intercom mic jack grounds to Point A as shown in Figure 4. (Use black washers supplied to insulate intercom mic jacks from aircraft chassis ground).

*D. Do NOT connect transmit switches to white (key) wire.

*E. Red wire may be connected to either 12 (14V) or 24 (28V) power source. No switching or adjustments are required to operate from either source.

*F. Tan wires from Pins 8 and 9 are only used on 4-way installations.

FINAL CHECKOUT AND ADJUSTMENT

After the unit is installed, again check that the intercom chassis, jacks, and wiring harness are clear of all aircraft operating controls and cause no interference with them. Check out the intercom functions by following the Operating Instructions.

It may be necessary at this time to adjust the intercom mic output to the aircraft radios. A small, square, adjustable trimmer potentiometer is provided inside the unit for this purpose. It is accessible through a hole in the side of the case, marked "Mod. Adj.", and can be adjusted with a screwdriver. In the event of overmodulation (garbled) or reports of weak transmissions over the aircraft radio, an appropriate adjustment can be made. Clockwise rotation increases the output level to the aircraft radio mic input. Counter-clockwise rotation decreases modulation level. This adjustment sometimes needs to be made after initial installation of the

PLUG PIN#	WIRE COLOR	FUNCTION	CONNECT TO:
1	White/Black	Pilot Mic Input	Ring Terminal of Pilot Intercom Mic Input Jack
2	White/Red *A	Pilot Transmit Switch Input	Pilot Transmit Switch (PTT) (Switch to Ground to Transmit)
3	Blue *B	Headphone - Radio and intercom Outputs	Radio Headphone Output and all intercom Outputs
4	Black *C	Ground	Hand Mic Jack Ground Terminal (Point A)
5	White *D	Transmit Relay (Key) Control Output	Tip Terminal of Aircraft Mic Jack or Key Input of Aircraft Radio or Audio Panel
6	Brown	Mic Audio Output	Ring Terminal of Aircraft Mic Jack or Input of Aircraft Radio or Audio Panel
7	Red *E	12 Through 24 VDC Power Input	Intercom Circuit Breaker
8	Tan *F	Passenger #1 Mic Input	Ring Terminal of Passenger #1 Mic Jack
9	Tan *F	Passenger #2 Mic Input	Ring Terminal of Passenger #2 Mic Jack
10	White/Blue	Co-Pilot Transmit Switch	Co-Pilot Transmit Switch (PTT)
11	White/Orange	Co-Pilot Mic Input	Ring Terminal of Intercom Co-Pilot Mic Input Jack
12			No Connection

Table 1 - *See Wiring Instructions

intercom or if a new radio is installed. (The output is set for unity gain at Sigtronics).

**Weight: Intercom with panel and knobs (4.5 oz.)
Jacks and wiring harness (5.5 oz. maximum)**
The SPA-400 is FAA-TSO approved (C-50b).
Env. Cat (D0-160) CFBBBX